



## **Be15xBe46 Software User Manual**

July 2006 - Be15XBe46 Software Release: 1.0.28

## **Be15 User Manual**

July 2006 - Be15 Firmware Release: 03.00.00.22

*The information in this document is subject to change without notice.  
No part of this document may be copied or reproduced in any form or any means without the prior written consent of Bernini Design company. Bernini Design assumes no responsibility for any errors which may appear in this instruction manual or in the wiring diagrams.  
Although Bernini Design has taken all possible steps to ensure that the User Manual is complete, bug free and up-to-date, we accept that errors may occur.*

**Customer Support** e-mail: [bernini@bernini-design.com](mailto:bernini@bernini-design.com) mobile: ++39 335 70 77 148

### **Warranty**

Bernini Design SRL (hereinafter "BD") warrants that BE15 shall be free from defect in material or workmanship for a period of 3 years from the BD delivery date. BD shall, at its option, repair or replace the product without charge. BD shall return the BE15 to the buyer with the Default parameters with no charge. The buyer shall furnish sufficient information on any alleged defects in the product so as to enable BD to determine their cause and existence. If the BE15 is not defective, or the product is defective for reason other than covered by this warranty, the buyer will be charged accordingly. This warranty shall not apply if the BE15 has not been used in accordance with the User Manual and other operating instruction, particularly if any defects are caused by misuse, improper repair attempts, negligence in use or handling. This purchase is non-refundable.

This equipment complies with the EMC protection requirements



## **BE15XBE46 OEM's Manual - Table of Contents**

<b>1.00 INTRODUCTION</b> .....	2
1.00 Setup for programming .....	3
2.00 Communication setting .....	3
3.00 Phonebook programming .....	4
3.01 Read the phonebook .....	4
3.02 Write the phonebook .....	5
3.03 Save the phonebook.....	5
3.04 Open the phonebook .....	5
4.00 SMS (Mobile Phone Messages) .....	6
4.01 Reading the SMS .....	6
4.02 Editing an SMS .....	6
4.03 SMS commands .....	7
5.00 BE46 and MODEM .....	9
6.00 Settings.....	10
6.01 Modbus address .....	10
6.02 Communication settings .....	10
6.03 Baud rate .....	10
6.04 Device name.....	11
6.05 BE46 disconnect time.....	11
6.06 Disconnect Time .....	11
6.07 Read settings.....	11
6.08 Write settings.....	11
7.00 MODBUS general information .....	11
8.00 Input register.....	12
8.01 Status register.....	12
8.02 Output registers .....	12
8.03 Parameter registers .....	13
8.04 Sensor settings register .....	14
8.05 Alarm registers.....	15
8.06 Serial number register .....	15
8.07 Phone book.....	16
9.00 Flag registers .....	18
10.00 Holding register .....	18
10.01 Parameter settings register .....	18
10.02 Sensor settings register .....	20
10.03 Serial number register .....	20
11.0 Coils.....	21
12.0 Notes .....	21
13.0 Typical application .....	22
14.0 Dimensions .....	23

### **Introduction**

The Be15 is an optional board for the Be46 controller. It provides:

- RS232 serial interface for the Be46 controller
- RS485 and MODBUS RTU protocol converter
- 15 programmable relay Outputs
- 2 x RS485 and 2 x RS232 connectors
- GSM and GPRS modem control
- 14 number Phonebook
- Programmable messages for mobile phone (SMS)
- SMS commands for genset control and monitoring
- Windows configurable software
- Modem interface and control (GSM and Analog)

This user manual allow you to configure the function of the BE15 when connected to a Be46 controller.

## 1.00 Setup for Be15 programming

- A) - Connect the BE15 module to the computer by means of serial cable (see drawing).
- B) - Set the jumper as indicated in the following drawing.
- C) - Power on the computer first; power on the Be15 (7Vdc up to 33Vdc) next.

Figure1: connections for Be15 setup

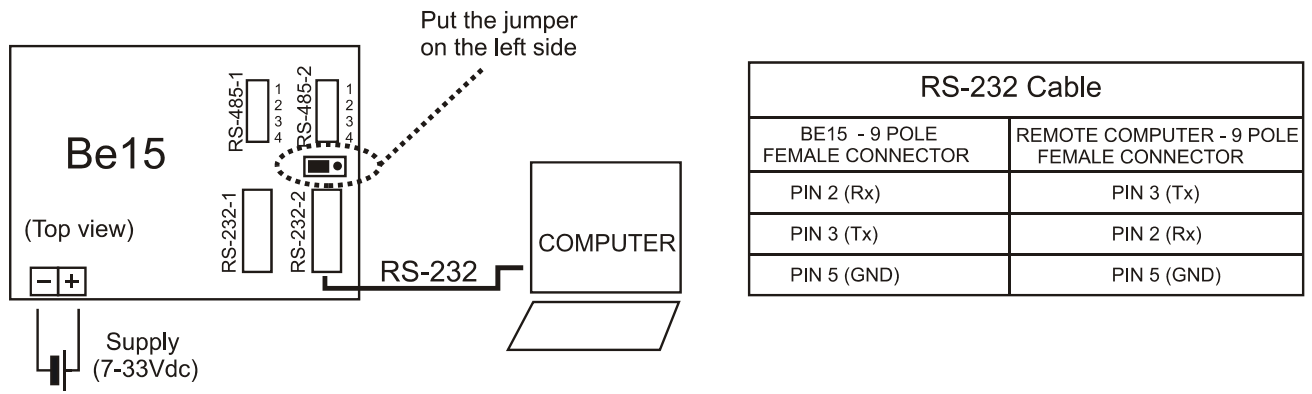

## 2.00 Communication settings

- A) - Run the Be15XBE46 software and select the COM port from the "Connection" menu.



- B) - Click "Connect" in order to make a communication.



### 3.0 Phonebook programming

The software features the following commands:



It is possible to create a phonebook of MOBILE PHONE numbers (in order to send SMS), or DATA NUMBERS (to communicate DATA). The Be15 will send an SMS in sequence to all numbers of the PHONEBOOK (marked as SMS numbers). After sending SMS, BE15 calls the DATA NUMBERS in sequence. The Be15 will call a location for a number of times specified in the "Retry Times" field. The interval time between the calling attempts is programmed in the "Delay AT" field.

#### 3.01 Read phonebook

A) – Click the “Read phonebook” button to display the numbers stored into Be15. The phonebook screen will be automatically updated.



### 3.02 Write Phonebook

- A) - Type the phone numbers into the box. Select the SMS or DATA option.
- B) - Click “Write phonebook” to save the phonebook into BE15.

The screenshot displays a 'PHONEBOOK' interface with 14 rows, each representing a phone entry. Each row contains a label (Phone1 through Phone14), a text input field for the phone number, and two radio buttons for selecting the communication method: 'SMS' and 'Data'. The 'SMS' radio button is selected for all entries. The first entry (Phone1) has the number '0040726687728' and the 'Data' radio button is selected. The fourth entry (Phone4) has the number '00232206199' and the 'Data' radio button is selected. Below the list of entries are four buttons: 'Write PhoneBook', 'Read PhoneBook', 'Open a File', and 'Save to a File'. A mouse cursor is pointing at the 'Write PhoneBook' button. At the bottom of the interface, a black terminal window shows the following text:

```
11:54:49> Writing phonebook. Please wait...
11:54:52> Write OK
11:54:52> Please wait to update phonebook
```

### 3.03 Save Phonebook

- A) - Click the “Save to a file” button to store the phonebook in a file of the computer.

### 3.04 Open Phonebook

- A) - Click the "Open a file" button to open the phonebook from a file of the computer.

## 4.00 SMS (Mobile Phone Messages)

### 4.01 Reading SMS

A) - In order to read the SMS text, push "Read SMS" button. The default text of the messages will appear on the left side.



### 4.02 Editing an SMS

- A) - Select the message that you want to edit from the left part of the window.
- B) - Type the new text in the edit box (over the Read SMS)
- C) - Push "Write SMS" to save the new text into BE15.

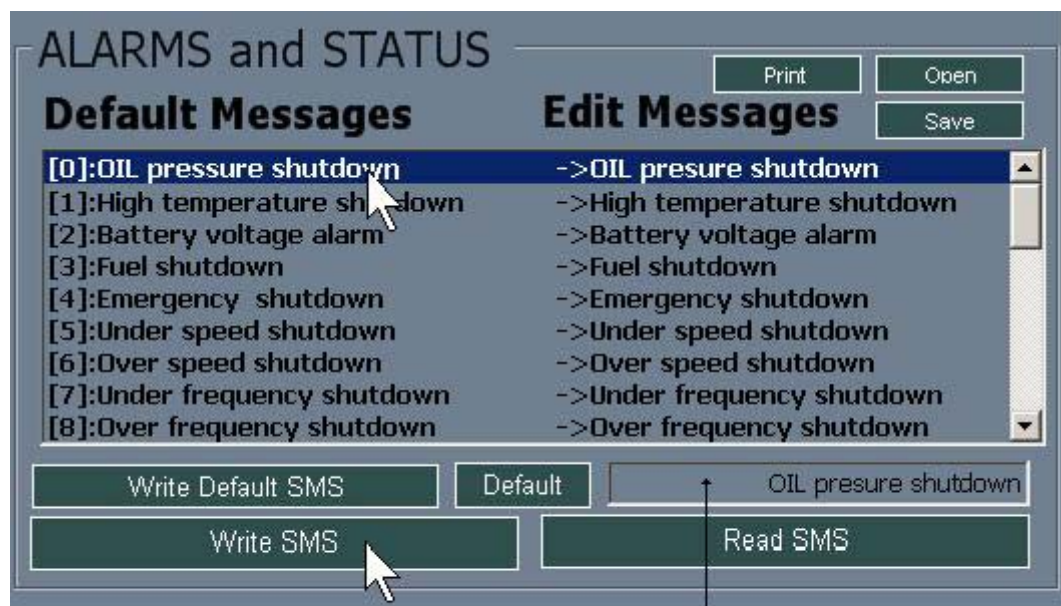

Type the name of the new SMS alarm

If you want to restore the original (default) SMS text, push the "Write default SMS" button.  
If you want to restore one SMS message follow the instruction:

- select the message from the left part of the window
- press the "Default" button
- press the "Write SMS" button to save the SMS message into BE15.

### 4.03 SMS commands

To send a command from your mobile phone to the BE15, use the following syntax:  
<DEVICE NAME > <COMMAND>.

**Example:** BE46 START ("BE46" is the <DEVICE NAME> and "START" is the name of the <COMMAND>).

The command will work only if the <DEVICE NAME > and Phone Number match the <DEVICE NAME > and Phone Number stored in the Be15.

To write the <DEVICE NAME >, follow the instructions in section 6.04.

The commands are listed below:

- |                              |   |
|------------------------------|---|
| <b>&lt;START&gt;:</b>        | Start Engine Command (only if BE46 is in AUTO operating mode).  |
| <b>&lt;STOP&gt;:</b>         | Stop Engine Command (only if BE46 is in AUTO operating mode).   |
| <b>&lt;STATUS&gt;:</b>       | Reads the status of the engine, operating mode, AMF input status, Generator status and KG (contactor of generator) status.  |
| <b>&lt;GENV&gt;:</b>         | Reads the following parameters: Voltage L1-L2, L2-L3, L1-L3 (three phase mode) or only L1-N (single phase mode), Current , and Generator Frequency.   |
| <b>&lt;GENP&gt;:</b>         | Reads the following parameters of the Generator: Power Factor, kVA, kW and kVAr.  |
| <b>&lt;ENGINE&gt;:</b>       | Reads the following parameters of the Engine: Battery Voltage, Speed, Oil Pressure, Fuel Level, Temperature, Hour-meter (the display of the mobile phone will not indicate parameters that are not configured in BE46, for example if sensors are not used) |
| <b>&lt;ALARM STATUS&gt;:</b> | Reads the status of the alarms.<br>The display can show up 3 alarms. If there are more than 3 alarms, the Be15 will send separate messages.   |
| <b>&lt;CLEAR&gt;:</b>        | Clears all alarms. If the Be46 is in AUTO operating mode, the engine can start again.   |

**Note** :

1. All SMS sent by the Be15 include the <DEVICE NAME > programmed into BE15.
2. The BE15 will send a message every time the number of the alarms in BE46 changes. The SMS shows all alarms that are active. The system will send you 2 or more messages if the number of the alarms is over 3. When all alarms disappear, the Be15 will send a message indicating that there are no alarms. The text of the message is: "<Device name>: No active alarms!".
3. BE15 will also send messages in the following cases:
  - BE15 loses, after a programmable time-out, the communication with BE46 (see section 6.00); The text of the message is: "BE46 is disconnected for more than <x> minute(s)!".
  - The level of the fuel changes more than 5% . (the text of the message is "Fuel level: <xx>%"). **Note:** the message indicates the operating mode, engine status and KG status.
  - The engine changes the status (the engine runs, stops or fails to stop); The text of the message is "Engine running!"/"Engine not running!"/"Fail to Stop". **Note:** the message will indicate the operating mode, the fuel level, and the KG status.
  - The Be46 changes the operating mode; The text of the message indicates one of the following: OFF / MANUAL / AUTO / PROGRAM / TEST LED / CALIBRATION". **Note:** the message will indicate the operating mode, the fuel level and the KG status.
  - The KG changes the status; The text of the message is "KG open "/"KG closed "). **Note:** the message will indicate the operating mode, the fuel level.

## 5.0 BE15 and MODEM

The figure 2 shows the connections. This configuration allow you to:

- control and monitor the BE46
- receive SMS (messages) on your mobile phone
- send SMS commands to the genset (see section 4.03)
- receive phone call for DATA transfer

Figure 2: Connection to a Modem

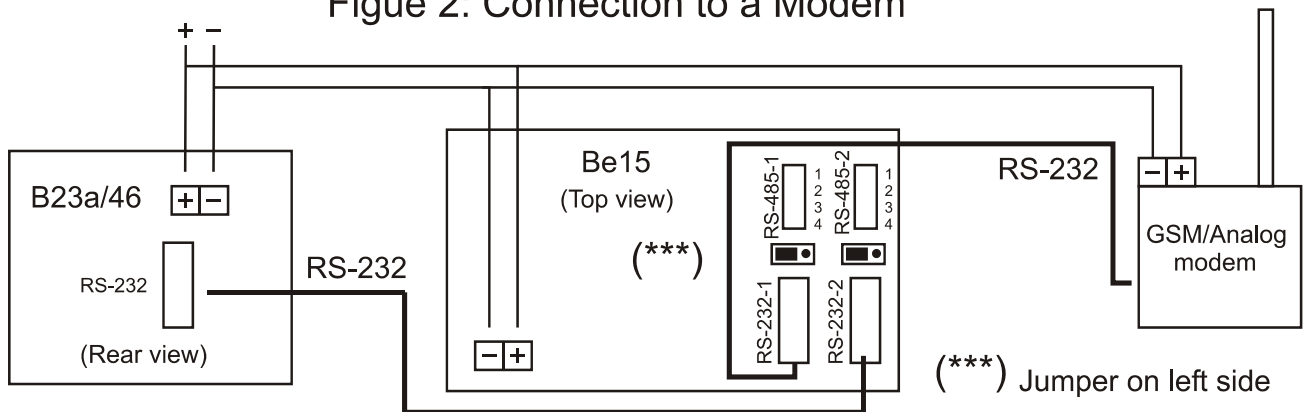

BeXX to Be15 connection cable	
BE23A/46 - 6 POLE FEMALE CONNECTOR	BE15 - 9 POLE FEMALE CONNECTOR
PIN 37 (Rx)	PIN 3 (Tx)
PIN 38 (Tx)	PIN 2 (Rx)
PIN 40 (GND)	PIN 5 (GND)

BE15 - 9 POLE FEMALE CONNECTOR	GSM MODEM - 9 POLE MALE CONNECTOR
PIN 1	PIN 1
PIN 2	PIN 2
PIN 3	PIN 3
PIN 4	PIN 4
PIN 5	PIN 5
PIN 6	PIN 6
PIN 7	PIN 7
PIN 8	PIN 8
PIN 9	PIN 9

## **WARNING**

- 1) Use a common negative supply
- 2) Before disconnecting or connecting cables remove the power supply
- 3) Use the shortest possible shielded cable
- 4) Limit the power supply of the Be15 to 33Vdc
- 5) Modem Supply: follow the recommendations of the Modem Manufacturer

## 6.0 Settings

The screen features the following indications and buttons:

The screenshot shows a settings interface for a device labeled BE15. It is divided into two main sections: 'Communication Settings' and 'Boud Rate'. In the 'Communication Settings' section, there are two radio buttons: '8N-1' (selected) and '8E-1'. In the 'Boud Rate' section, there are two radio buttons: '9600' (selected) and '19200'. Below these sections are several numeric input fields: 'Delay AT:' (1), 'Disconnect Time:' (60), 'Retry Times:' (1), 'Mod Bus Address:' (1), and 'BE46 Disconnect Time:' (5). There is also a 'Device Name:' field containing 'BE15'. At the bottom, there are two buttons: 'Write Settings' and 'Read Settings'.

### MODBUS settings

#### 6.01 Modbus address

Set the Modbus address of BE15 in a range 1 to 247 in the field “Modbus Address”. Push the “Write Settings” button in order to save the settings in the BE15 memory.

#### 6.02 Communication settings

Select the communication format .

- options:
- 8N-1 (8 data bits; parity none; 1 stop bit)
  - 8E-1 (8 data bits; parity even; 1 stop bit).

After selecting the desired format, push the “Write Settings” button in order to save the settings in the Be15 memory. This setting affects only RS232-1/RS485-1.

#### 6.03 Baud Rate

Select the baud rate between 9600 bps and 19200 bps. This setting affects only RS232-1/RS485-1. Push the “Write Settings” button in order to save the settings in the memory of BE15. If you use RS232-1, for connecting a GSM modem, set the baud rate to 9600 bps.

## **OTHER settings**

### **6.04 Device name**

The <DEVICE NAME> will be included in all messages. The BE15 will accept an SMS command only if the <DEVICE NAME> sent by the mobile phone matches the <DEVICE NAME> stored in the BE15. Type the <DEVICE NAME> in the box over the READ SETTING button (see section 6.0). The software will accept up to 9 characters (capital letters and numbers).

### **6.05 Be46 disconnect time**

This is the time-out programming to detect the failure of communication between Be15 and Be46. After this time Be15 will send an SMS to announce the FAILURE.

### **6.06 Disconnect Time**

The communication will automatically close if, after the “Disconnect Time” time-out, the Be15 does not detect data on the line.

### **6.07 Read settings**

Click the “Read settings” button to read the settings saved in BE15. The settings are automatically updated the first time you connect.

### **6.08 Write settings**

Click the “Write settings” button to save the settings into BE15.

## **7.0 MODBUS general information**

The communication protocol meets the MODBUS RTU convention and includes the following function codes:

Code	Function
01	Read coils
03	Read holding registers
04	Read input registers
05	Write single coil
06	Write single register
10	Write multiple registers

Communication speed: 9600 baud/19200 baud

Data bits: 8

Parity: none/even

Stop bits: 1

Flow control: none

Device address: 1 (default)

To change the Modbus address see the section 6.01.

Full information on the MODBUS RTU can be found at [www.modbus.org](http://www.modbus.org)

## 8.0 Input register

### 8.01 STATUS register (for NOTE see section 12.0)

REGISTER	FORMAT	DESCRIPTION	Units	Notes
30000	xxxx	Voltage L1L2	Vac	
30001	xxxx	Voltage L2L3	Vac	
30002	xxxx	Voltage L3L1	Vac	
30003	xxxx	Current	Aac	7
30004	xxxx	Frequency Generator	Hz	1
30005	xxxx	Power factor		9
30006	xxxx	KVA	KVA	7
30007	xxxx	KW	KW	7
30008	xxxx	KVAR	KVAR	7
30009	xxxx	Battery	Vdc	1
30010	xxxx	Speed	r.p.m.	
30011	xxxx	Pressure	bar	1
30012	xxxx	Temperature	°C	
30013	xxxx	Fuel	%	
30014	xxxx	Hours	hours	
30015	xxxx	Engine run	Vdc	1
30033	x	Inhibit Teeth Number		
30034	x	Phases		
30035	x	Mains status		1
30036	x	Generator status		2
30037	x	Operating mode		3
30038	x	Engine status		4
30039	x	KM status		5
30040	x	KG status		5
30041	x	Remote start status		
30042	x	Engine test status		
30043	x	Mains bypass status		
30044	x	Start from PC status		
30045	x	Battery type		
30046	x	Trimit X		

### 8.02 Output register

REGISTER	FORMAT	DESCRIPTION	Note
30016	X	Output 1 Be46	19
30017	X	Output 2 Be46	19
30018	X	Output 1 Be15	20
30019	X	Output 2 Be15	20
30020	X	Output 3 Be15	20
30021	X	Output 4 Be15	20
30022	X	Output 5 Be15	20
30023	X	Output 6 Be15	20
30024	X	Output 7 Be15	20
30025	X	Output 8 Be15	20
30026	X	Output 9 Be15	20
30027	X	Output 10 Be15	20

30028	X	Output 11 Be15	20
30029	X	Output 12 Be15	20
30030	X	Output 13 Be15	20
30031	X	Output 14 Be15	20
30032	X	Output 15 Be15	20

### 8.03 PARAMETERS register

REGISTER	FORMAT	DESCRIPTION	Notes
30047	xx	Alarm Timing	8
30048	xx	Mains Failure	8
30049	xx	Mains Restore	8
30050	xx	Cooling Timing	8
30051	xx	StopTiming	8
30052	xx	Pre-glow	
30053	xx	Engine warm up	
30054	xxxx	CT Size	
30055	xxxx	Max Current	
30056	xxxx	Min Voltage	
30057	xxxx	Max Voltage	
30058	x	Phases	
30059	x	VoltageFactor	
30060	xxxx	Max KVA	
30061	xxx	Min Hz	1
30062	xxx	Max Hz	1
30063	xxxx	Min Speed	
30064	xxxx	Max Speed	
30065	xxx	Speed Threshold	
30066	xxxx	Teeth Number	
30067	xxx	Engine Runnig detect	1
30068	xxx	Min Pressure	1
30069	xxx	Max Temperature	
30070	xx	Mask_oil_time	
30071	xx	Spare1	
30072	xx	Spare2	
30073	x	Polarity1	
30074	x	Polarity2	
30075	x	Polarity of the Emergency contact	
30076	x	Polarity input 3	
30077	xxx	Fuel Threshold	
30078	x	option 1	
30079	x	option 2	
30080	xx	Number of the Attempts	
30081	xx	Crank timing	
30082	xx	Rest timing	
30083	xx	Crank delay timing	
30084	xxx	GenSet Timeout	

30085	xx	be15_output1	
30086	xx	be15_output2	
30087	xx	be15_output3	
30088	xx	be15_output4	
30089	xx	be15_output5	
30090	xx	be15_output6	
30091	xx	be15_output7	
30092	xx	be15_output8	
30093	xx	be15_output9	
30094	xx	be15_output10	
30095	xx	be15_output11	
30096	xx	be15_output12	
30097	xx	be15_output13	
30098	xx	be15_output14	
30099	xx	be15_output15	
30100	x	Unit number (node address)	

## 8.04 Sensor settings register

REGISTER	FORMAT	DESCRIPTION	Default
30101	xxxx	Fuel sensor point 1 – ohm	10
30102	xxxx	Fuel sensor point 1 – %	0
30103	xxxx	Fuel sensor point 2 – ohm	50
30104	xxxx	Fuel sensor point 2 – %	20
30105	xxxx	Fuel sensor point 3 – ohm	100
30106	xxxx	Fuel sensor point 3 – %	50
30107	xxxx	Fuel sensor point 4 – ohm	150
30108	xxxx	Fuel sensor point 4 – %	80
30109	xxxx	Fuel sensor point 5 – ohm	200
30110	xxxx	Fuel sensor point 5 – %	90
30111	xxxx	Fuel sensor point 6 – ohm	250
30112	xxxx	Fuel sensor point 6 – %	99
30113	xxxx	Pressure sensor point 1 – ohm	0
30114	xxxx	Pressure sensor point 1 – bar (NOTE 1)	10
30115	xxxx	Pressure sensor point 2 – ohm	2.0
30116	xxxx	Pressure sensor point 2 – bar (NOTE 1)	51
30117	xxxx	Pressure sensor point 3 – ohm	4.0
30118	xxxx	Pressure sensor point 3 – bar (NOTE 1)	86
30119	xxxx	Pressure sensor point 4 – ohm	6.0
30120	xxxx	Pressure sensor point 4 – bar (NOTE 1)	122
30121	xxxx	Pressure sensor point 5 – ohm	8.0
30122	xxxx	Pressure sensor point 5 – bar (NOTE 1)	152
30123	xxxx	Pressure sensor point 6 – ohm	10.0
30124	xxxx	Pressure sensor point 6 – bar (NOTE 1)	180
30125	xxxx	Temperature sensor point 1 – ohm	19
30126	xxxx	Temperature sensor point 1 – C	128
30127	xxxx	Temperature sensor point 2 – ohm	26
30128	xxxx	Temperature sensor point 2 – C	115
30129	xxxx	Temperature sensor point 3 – ohm	46
30130	xxxx	Temperature sensor point 3 – C	92

30131	xxxx	Temperature sensor point 4 – ohm	67
30132	xxxx	Temperature sensor point 4 – C	80
30133	xxxx	Temperature sensor point 5 – ohm	96
30134	xxxx	Temperature sensor point 5 – C	70
30135	xxxx	Temperature sensor point 6 – ohm	287
30136	xxxx	Temperature sensor point 6 – C	40

### 8.05 Alarm registers

REGISTER	FORMAT	DESCRIPTION	Notes
30137	x	OIL pressure shutdown	
30138	x	High temperature shutdown	
30139	x	Battery voltage alarm	
30140	x	Fuel shutdown	
30141	x	Emergency shutdown	
30142	x	Under speed shutdown	
30143	x	Over speed shutdown	
30144	x	Under frequency shutdown	
30145	x	Over frequency shutdown	
30146	x	Belt failure shutdown	
30147	x	Under voltage shutdown	
30148	x	Over voltage shutdown	
30149	x	Current over the limit	
30150	x	Power over the limit	
30151	x	FAIL to START shutdown	
30152	x	PICK-UP failure	
30153	x	Alternator failure	
30154	x	Memory error	
30155	x	Oil pressure warning	
30156	x	High temperature warning	
30157	x	Oil sensor failure	
30158	x	Temperature sensor failure	
30159	x	FUEL level warning	
30160	x	FUEL level alarm	
30161	x	Auxiliary alarm INPUT 4 shutdown	

### 8.06 Serial number register

REGISTER	FORMAT	DESCRIPTION
30162	x	x = 1 of the 13 digits from the serial number (default serial number 0000000000000)
30163	x	
30164	x	
30165	x	
30166	x	
30167	x	
30168	x	
30169	x	
30170	x	
30171	x	
20172	x	
30173	x	
30174	x	

## 8.07 Phone book

REGISTER	FORMAT	DESCRIPTION
30240	XXXXX	Note 1
30241	XXXXX	Note 2
30242	XXXXX	Note 2
30243	XXXXX	Note 2
30244	XXXXX	Note 2
30245	XXXXX	Note 2
30246	XXXXX	Note 1
30247	XXXXX	Note 2
30248	XXXXX	Note 2
30249	XXXXX	Note 2
30250	XXXXX	Note 2
30251	XXXXX	Note 2
30252	XXXXX	Note 1
30253	XXXXX	Note 2
30254	XXXXX	Note 2
30255	XXXXX	Note 2
30256	XXXXX	Note 2
30257	XXXXX	Note 2
30258	XXXXX	Note 1
30259	XXXXX	Note 2
30260	XXXXX	Note 2
30261	XXXXX	Note 2
30262	XXXXX	Note 2
30263	XXXXX	Note 2
30264	XXXXX	Note 1
30265	XXXXX	Note 2
30266	XXXXX	Note 2
30267	XXXXX	Note 2
30268	XXXXX	Note 2
30269	XXXXX	Note 2
30270	XXXXX	Note 1
30271	XXXXX	Note 2
30272	XXXXX	Note 2
30273	XXXXX	Note 2
30274	XXXXX	Note 2
30275	XXXXX	Note 2
30276	XXXXX	Note 1
30277	XXXXX	Note 2
30278	XXXXX	Note 2
30279	XXXXX	Note 2
30280	XXXXX	Note 2
30281	XXXXX	Note 2
30282	XXXXX	Note 1
30283	XXXXX	Note 2
30284	XXXXX	Note 2
30285	XXXXX	Note 2
30286	XXXXX	Note 2
30287	XXXXX	Note 2
30288	XXXXX	Note 1
30289	XXXXX	Note 2

30290	XXXXX	Note 2
30291	XXXXX	Note 2
30292	XXXXX	Note 2
30293	XXXXX	Note 2
30294	XXXXX	Note 1
30295	XXXXX	Note 2
30296	XXXXX	Note 2
30297	XXXXX	Note 2
30298	XXXXX	Note 2
30299	XXXXX	Note 2
30300	XXXXX	Note 1
30301	XXXXX	Note 2
30302	XXXXX	Note 2
30303	XXXXX	Note 2
30304	XXXXX	Note 2
30305	XXXXX	Note 2
30306	XXXXX	Note 1
30307	XXXXX	Note 1
30308	XXXXX	Note 2
30309	XXXXX	Note 2
30310	XXXXX	Note 2
30311	XXXXX	Note 2
30312	XXXXX	Note 2
30313	XXXXX	Note 1
30314	XXXXX	Note 2
30315	XXXXX	Note 2
30316	XXXXX	Note 2
30317	XXXXX	Note 2
30318	XXXXX	Note 2
30319	XXXXX	Note 1
30320	XXXXX	Note 2
30321	XXXXX	Note 2
30322	XXXXX	Note 2
30323	XXXXX	Note 2
30324	XXXXX	Note 2
30325	XXXXX	Note 1
30326	XXXXX	Note 2
30327	XXXXX	Note 2
30328	XXXXX	Note 2
30329	XXXXX	Note 2

**Note 1**

Register part	Format	Description
High byte	XXX (decimal)	First X define the type of phone number: 0 = no number 1 = SMS number 2 = data number Last two XX is the number of digits of the phone number ( 21 digits max )
Low byte	XX (decimal)	2 digits of the phone number

**Note 2**

Register part	Format	Description
---------------	--------	-------------

High byte	XX	Each X is a digit of the phone number
Low byte	XX	

**Example of phone number encoding:**

Phone number 1: 0745217307    Type: SMS number

Register 30639 = 256 \* high\_byte + low\_byte = 28167  
high\_byte=110 (1 for SMS type and 10 for the number of digits)  
low\_byte=07

Register 30640 = 256 \* high\_byte + low\_byte = 11541  
high\_byte=45  
low\_byte=21

Register 30641 = 256 \* high\_byte + low\_byte = 18695  
high\_byte=73  
low\_byte=07

**9.0 Flag registers**

Register	Format	Description	Note
30230	x	Mem init flag register	0 -Command not processed
30231	x	Genset start flag register	1 - OK, Mem init ok, Write ok
30232	x	Engine stop flag register	2 - CHKERR, ERROR, MEM init error
30233	x	Engine start flag register	3 - Range error
30234	x	Clear alarms flag register	4- START UNAVAILABLE
30235	x	Write parameters flag register	5 - STOP UNAVAILABLE
30236	x	Write sensors flag register	
30237	x	Write serial number flag register	

**10.0 Holding registers**

**10.01 Parameters settings register**

REGISTER	FORMAT	DESCRIPTION	Notes
40170	xx	AlarmTime	8
40171	xx	Mains Failure	8
40172	xx	Mains Restore	8
40173	xx	CoolingTime	8
40174	xx	StopTime	8
40173	xx	Preaheat	
40176	xx	TimeGenerator	
40177	xxxx	CTSize	
40178	xxxx	MaxCurrent	
40179	xxxx	MinVoltage	
40180	xxxx	MaxVoltage	
40181	x	Phases	

40182	x	VoltageFactor	
40183	xxxx	Max KVA	
40184	xxx	Min Hz	1
40185	xxx	Max Hz	1
40186	xxxx	Min Speed	
40187	xxxx	Max Speed	
40188	xxx	Speed Threshold	
40189	xxxx	Teeth Number	
40190	xxx	Engine Run Threshold	1
40191	xxx	Min Pressure	1
40192	xxx	Max Temperature	
40193	xx	Mask_oil_time	
40194	xx	Spare1	
40195	xx	Spare2	
40196	x	Polarity1	
40197	x	Polarity2	
40198	x	Polarity Emergency switch	
40199	x	Polarity input 3	
40200	xxx	Fuel Threshold	
40201	x	option1	
40202	x	option2	
40203	xx	Attempts	
40204	xx	Crank	
40205	xx	Rest	
40206	xx	Crank delay	
40207	xxx	Gen Set test Timeout	
40208	xx	be15_output1	
40209	xx	be15_output2	
40210	xx	be15_output3	
40211	xx	be15_output4	
40212	xx	be15_output5	
40213	xx	be15_output6	
40214	xx	be15_output7	
40215	xx	be15_output8	
40216	xx	be15_output9	
40217	xx	be15_output10	
40218	xx	be15_output11	
40219	xx	be15_output12	
40220	xx	be15_output13	
40221	xx	be15_output14	
40222	xx	be15_output15	
40223	x	Unit number	

## 10.02 Sensor settings register

REGISTER	FORMAT	DESCRIPTION	Default
40224	xxxx	Fuel sensor point 1 – ohm	10
40225	xxxx	Fuel sensor point 1 – %	0
40226	xxxx	Fuel sensor point 2 – ohm	50
40227	xxxx	Fuel sensor point 2 – %	20
40228	xxxx	Fuel sensor point 3 – ohm	100
40229	xxxx	Fuel sensor point 3 – %	50
40230	xxxx	Fuel sensor point 4 – ohm	150
40231	xxxx	Fuel sensor point 4 – %	80
40232	xxxx	Fuel sensor point 5 – ohm	200
40233	xxxx	Fuel sensor point 5 – %	90
40234	xxxx	Fuel sensor point 6 – ohm	250
40235	xxxx	Fuel sensor point 6 – %	99
40236	xxxx	Pressure sensor point 1 – ohm	0
40237	xxxx	Pressure sensor point 1 – bar (NOTE 1)	10
40238	xxxx	Pressure sensor point 2 – ohm	2.0
40239	xxxx	Pressure sensor point 2 – bar (NOTE 1)	51
40240	xxxx	Pressure sensor point 3 – ohm	4.0
40241	xxxx	Pressure sensor point 3 – bar (NOTE 1)	86
40242	xxxx	Pressure sensor point 4 – ohm	6.0
40243	xxxx	Pressure sensor point 4 – bar (NOTE 1)	122
40244	xxxx	Pressure sensor point 5 – ohm	8.0
40245	xxxx	Pressure sensor point 5 – bar (NOTE 1)	152
40246	xxxx	Pressure sensor point 6 – ohm	10.0
40247	xxxx	Pressure sensor point 6 – bar (NOTE 1)	180
40248	xxxx	Temperature sensor point 1 – ohm	19
40249	xxxx	Temperature sensor point 1 – C	128
40250	xxxx	Temperature sensor point 2 – ohm	26
40251	xxxx	Temperature sensor point 2 – C	115
40252	xxxx	Temperature sensor point 3 – ohm	46
40253	xxxx	Temperature sensor point 3 – C	92
40254	xxxx	Temperature sensor point 4 – ohm	67
40255	xxxx	Temperature sensor point 4 – C	80
40256	xxxx	Temperature sensor point 5 – ohm	96
40257	xxxx	Temperature sensor point 5 – C	70
40258	xxxx	Temperature sensor point 6 – ohm	287
40259	xxxx	Temperature sensor point 6 – C	40

## 10.03 Serial number registers

REGISTER	FORMAT	DESCRIPTION
40260	x	x = 1 of the 13 digits from the serial number
40261	x	
40262	x	
40263	x	
40264	x	
40265	x	
40266	x	

40267	x	
40268	x	
40269	x	
40270	x	
40271	x	
40272	x	

## 11.0 Coils

COIL	VALUE	DESCRIPTION
20	any	Clear alarms
21	any	Start engine
22	any	Stop engine
23	any	Genset start
24	any	MEM INIT

## 12.0 Notes

Note	Description
1	Must be divided by 10
2	0 - not available, 1 - phase error, 2 - phase ok
3	1 – OFF, 2 – TEST LED, 3 - MANUAL, 4 – AUTO, 5 - PROGRAM, 6 - CALIBRATION
4	0 – Not running, 1 – STARTING, 2 – ENGINE RUNNING, 3 - Cooling down 4 - STOPPING, 5 – STOPPED , 6 - FAIL TO STOP
5	0 – open                      1 – close
6	0 – No test                    1 – Test
7	If CT size is smaller or equal to 100, divide the value by 10
8	Time encoding: 0 to 59 seconds, > 60=minutes, encoding: minutes = value – 59
9	The value must be divisible by 100
18	0: off    1: on    2: alarm acknowledge
19	0 – Off                      1 – On
20	<div style="display: flex; justify-content: space-between;"> <div style="width: 45%;"> <p>[0]:Low Oil Pressure shutdown [1]:High temperature shutdown [2]:BATTERY voltage alarms [3]:Fuel level switch shutdown [4]:Emergency shutdown [5]:Under Speed shutdown [6]:Over speed shutdown [7]:Under Frequency shutdown [8]:Over Frequency shutdown [9]:BELT failure shutdown [10]:Under Voltage shutdown [11]:Over Voltage shutdown [12]:Over Current shutdown [13]:POWER over the limit [14]:FAIL to START shutdown [15]:PICK-UP failure warning [16]:Alternator Failure shutdown [17]:Memory Error [18]:Low Oil Pressure warning [19]:High Temperature warning [20]:Oil Sensor failure [21]:Temperature sensor failure [22]:FUEL LEVEL switch warning [23]:FUEL LEVEL sensor warning</p> </div> <div style="width: 45%;"> <p>[24]:Auxiliary alarm INPUT 4 shutdown [25]:AUTO operating mode status [26]:Engine Running status [27]:Oil press./Engine temperature warnings [28]:Low Oil pressure shutdown [29]:High temperature shutdown [30]:Fail to Stop status [31]:Fuel warnings and shutdowns [32]:Emergency shutdown or Input-4 [33]:Speed /Frequency errors or shutdowns [34]:Alternator voltage alarm (Lo-V or Hi-V or Alternator Failure) [35]:Overload shutdown (Hi-I or Hi-P) [36]:FAIL to START shutdown [37]:BELT failure shutdown [38]:Mains contactor CLOSED (KM=ON) [39]:Preglow 1 mode [40]:Generator KG =ON [41]:MANUAL mode [42]:OFF mode [43]:MAINS-FAULT [44]:MAINS-RESTORE [45]:INHIBIT</p> </div> </div>

## Section 13: wiring diagram

Figure 3: Be23/46 - Modem connections

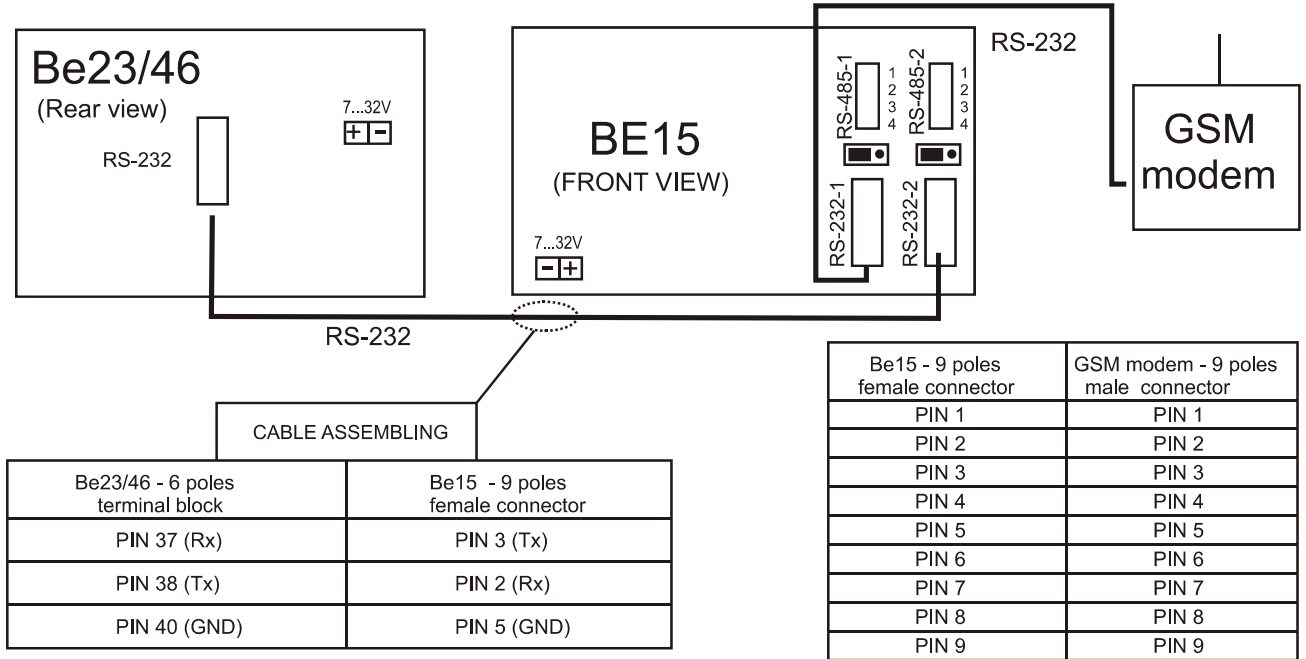
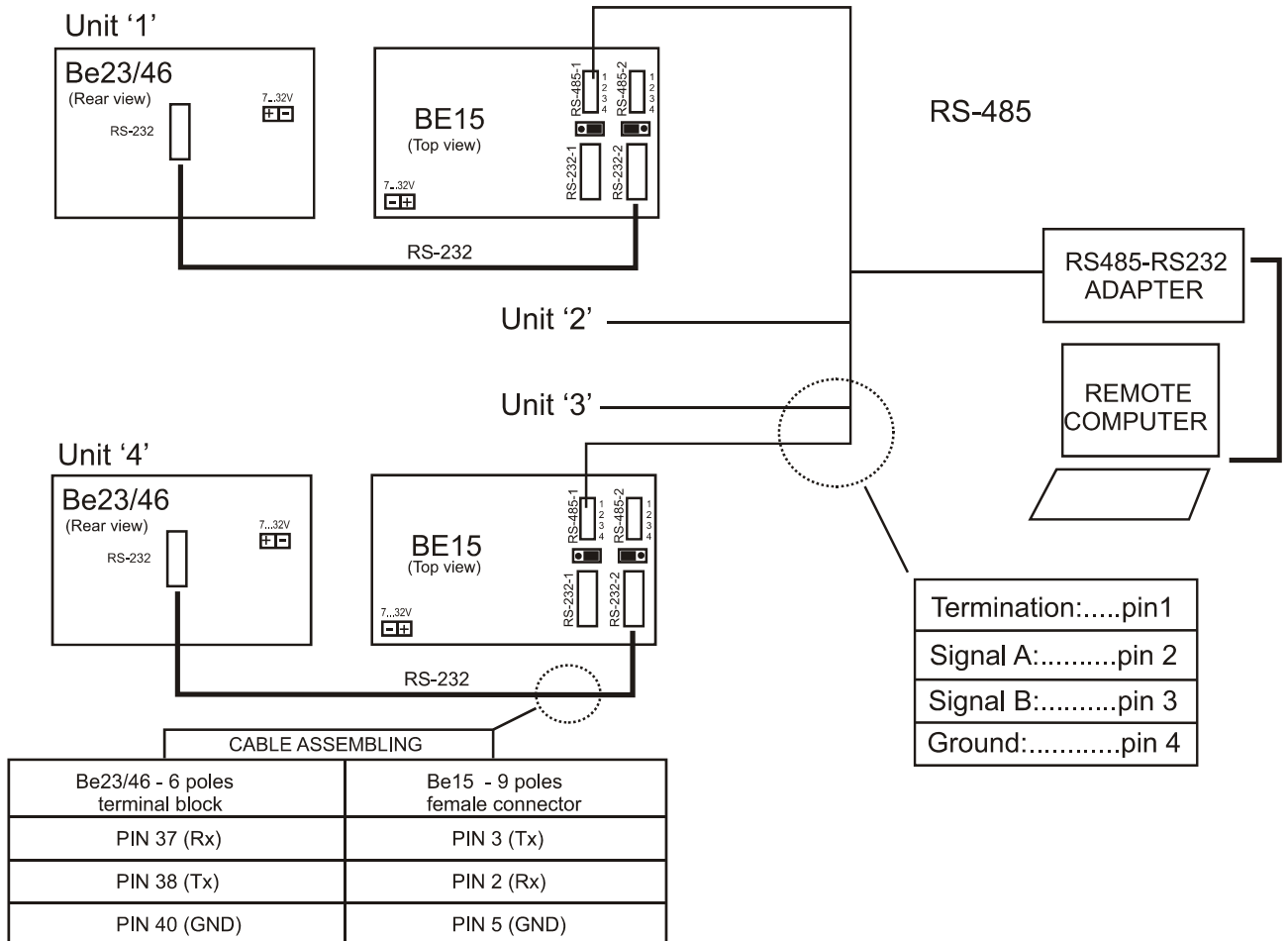

Figure 4: Be23/46 - RS-485 (MODBUS) example of connection of 4 units



Section 14.0: Be15 Dimensions and connection table

Connections

1 +Vdc (6-36V)  
2 -Vdc (ground)

N.O.	Common	N.C.	Output
3	4	5	15
6	7	8	14
9	10	11	13
12	13	14	12
15	16	17	11
18	19	20	10
21	22	23	9
24	25	26	8
27	28	29	7
30	31	32	6
33	34	35	5
36	37	38	4
39	40	41	3
42	43	44	2
45	46	47	1

(contact ratings: 8A-30Vdc)

