

# Be-One OEM's Manual

*The information in this document is subject to change without notice.*

*No part of this document may be copied or reproduced in any form or any means without the prior written consent of Bernini Design Company. Bernini Design assumes no responsibility for any errors which may appear in this instruction manual or in the wiring diagrams.*

*Although Bernini Design has taken all possible steps to ensure that the User Manual is complete, bug free and up-to-date, we accept that errors may occur. If you encounter problems with this instruction manual, please complete this form and send it back to us.*

## Customer Support BERNINI DESIGN SRL ITALY

e-mail: [bernini@bernini-design.com](mailto:bernini@bernini-design.com)

Mobile (main): ++39 335 7077148. Tel:++39 0386-31445 (fax 31657).

Mobile (aux.): ++40 721 241361

## Warranty

Bernini Design SRL (hereinafter "BD") warrants that Be-ONE shall be free from defect in material or workmanship for a period of 3 years from the BD delivery date. BD shall, at its option, repair or replace the product without charge. BD shall return the Be-ONE to the buyer with the Default parameters at no extra charge. The buyer shall furnish sufficient information on any alleged defects in the product, so as to enable BD to determine their cause and existence. If the Be-ONE is not defective, or the product is defective for reason other than covered by this warranty, the buyer will be charged accordingly. This warranty shall not apply if the Be-ONE has not been used in accordance with the User Manual and other operating instruction, particularly if any defects are caused by misuse, improper repair attempts, negligence in use or handling. The warranty does not include the membrane keyboard (front panel) in case of visible signs of misuse. This purchase is non-refundable.

This equipment complies with the EMC protection requirements



**WARNING!! High voltage is present inside the Be-ONE. To avoid electric-shock hazard, operating personnel must not remove the protective cover. Do not disconnect the grounding connection. The Be-ONE can start the engine at anytime. Do not work on equipment, which is controlled by the Be-ONE. When servicing the engine, disconnect the battery and battery charger. We recommend that warning signs be placed on equipment indicating the above.**

**!! W A R N I N G !! Relays and solenoids connected to the Be-ONE must be suppressed using flywell diodes or suppression devices as indicated in section 17.0.**

**Alphabetic index**

<b>Alarms</b> ..... 4.10, 8.0	<b>Manual</b> .....2.2
<b>Alarm output (Horn)</b> ..... 7.08, option[ 4 ]	<b>Node address</b> .....7.06 [P.47]
<b>Alarm inputs</b> .....7.07A-B	<b>Oil pressure</b> .....7.03B [P.29]
<b>Automatic</b> ..... 2.3	<b>Outputs (programmable)</b> ....7.09
<b>Battery, Alarms</b> .....4.10 [bAtt]	<b>Operating modes</b> .....2.0
<b>Belt break</b> .....4.10 [bELt]	<b>Over Voltage</b> ..... Table 7.01
<b>Choke, control</b> .....7.03B [P22]	<b>Over Frequency</b> ..... Table 7.01
<b>Calibration</b> ..... 11.0	<b>Parameters</b> .....7.0
<b>Characteristics</b> ..... 13.0	<b>Parameters reading</b> .....6.30
<b>Charger Alternator</b> ..... 10.0, 7.03B [P24]	<b>Periodic test</b> .....7.06
<b>Contactors</b> .....7.08B, option[6]	<b>Program, Programming</b> .....6.0
<b>Connectors, Plugs</b> ..... 19.0	<b>Pre Glow</b> .....7.03B [P22]
<b>Connections</b> ..... 19.0	<b>Power Supply</b> ..... 13.0
<b>Crank timing</b> .....7.03A [P17]	<b>Push buttons</b> .....2.0, 2.2
<b>Cooling down time</b> .....7.03B [P28]	<b>Rest time</b> .....7.03A [P18]
<b>Defaults</b> ..... 6.20	<b>R.P.M.</b> .....7.02
<b>Dimensions</b> ..... 18.0	<b>Service (Maintenance)</b> .....7.06 [P46]
<b>Display</b> ..... 3.0	<b>Settings (Parameters)</b> .....7.0
<b>Display Messages</b> ..... 4.10, 4.20	<b>Specifications</b> ..... 13.0
<b>Error codes</b> ..... 4.10	<b>Software upgrade</b> ..... 14.0
<b>Engine Running</b> ..... 10.0	<b>Start</b> ..... 2.2
<b>Emergency input</b> .....7.07B, option[6]	<b>Start Attempts</b> .....7.03A [P19]
<b>Event history</b> ..... 8.1	<b>Starting Failure</b> .....8.0
<b>Fail to Start</b> ..... 4.10 [F.Str]	<b>Stop, Stop solenoid</b> .....7.08B [P23]
<b>Fail to Stop</b> ..... 4.10 [F.StP]	<b>Temperature</b> .....7.03B [P36]
<b>Front Panel</b> ..... 1.0	<b>Terminal description</b> ..... 19.0
<b>Fuel Level</b> .....7.05	<b>Test, Periodic Test</b> .....7.06 [P44] [P45]
<b>Generator Failure [ALt.]</b> ... 4.10	<b>Test mode</b> ..... 2.4
<b>Glow Plugs</b> .....7.03B [P22]	<b>Under Speed</b> .....7.02
<b>Hour Counter</b> ..... 9.0	<b>Under Voltage</b> ..... Table 7.01
<b>Inputs (Programmable)</b> .... 7.07-7.13	<b>Under Frequency</b> ..... Table 7.01
<b>LED, LEDs</b> ..... 5.0	<b>Voltage measurements</b> .....3.0
<b>Lamp Test</b> ..... 5.1	<b>Warm-Up time</b> .....7.03B [P27]
<b>Low Battery voltage</b> ..... 4.10 [bAtt]	<b>Wiring diagram</b> ..... 17.0
<b>Maintenance</b> ..... 7.06 [P46]	
<b>Measurements</b> ..... 3.0	
<b>Memory clear, restore</b> ..... 11.3	
<b>Messages (Display)</b> ..... 4.0	

## **Be-One OEM's Manual - Contents**

<b>1.0 Introduction</b> .....	<b>page 4</b>
<b>2.0 Mode selection</b> .....	<b>page 4</b>
2.1 OFF mode.....	page 5
2.2 MANUAL mode.....	page 5
2.3 AUTO mode.....	page 5
2.4 TEST mode.....	page 5
<b>3.0 DISPLAY measurements</b> .....	<b>page 5</b>
<b>4.0 DISPLAY messages</b> .....	<b>page 6</b>
<b>5.0 LED indicators</b> .....	<b>page 8</b>
5.1 Lamp and Display Test .....	page 8
<b>6.0 PROGRAMMING &amp; READING parameters</b> .....	<b>page 8</b>
6.10 Enter the Programming Mode.....	page 8
6.11 Enter the password.....	page 8
6.12 Programming .....	page 8
6.13 Saving.....	page 8
6.14 Exit without saving.....	page 9
6.20 Re-programming default settings .....	page 9
6.30 Reading the parameters.....	page 9
6.40 Activating the password.....	page 9
6.50 Changing the password.....	page 9
6.60 Removing the password.....	page 10
<b>7.0 Programmable Parameters</b> .....	<b>page 10</b>
Table 7.00 Remote control.....	page 10
Table 7.01 Generator Parameters .....	page 11
Table 7.02 Speed Settings .....	page 11
Table 7.03A-B Engine Control .....	page 11-12
Table 7.04 Alarm Options.....	page 12
Table 7.05 Fuel Alarms .....	page 13
Table 7.06 Miscellaneous.....	page 13
Table 7.07A Programming of the Inputs.....	page 13
Table 7.08A Programming of the Outputs.....	page 14
Table 7.08B Outputs Options table .....	page 15
Table 7.09 Oil Pressure Sensor .....	page 15
Table 7.10 Fuel Level Sensor.....	page 15
Table 7.11 Coolant temperature Sensor .....	page 15
Table 7.12 Oil temperature Sensor .....	page 15
Table 7.13 Canopy temperature Sensor .....	page 15
<b>8.0 Alarms, Warnings &amp; Shutdowns</b> .....	<b>page 16</b>
8.1 Event History.....	page 16
<b>9.0 Hour Meter</b> .....	<b>page 16</b>
<b>10.0 Engine Running detect (charger alternator)</b> .....	<b>page 17</b>
<b>11.0 Calibration and Memory Reset</b> .....	<b>page 17</b>
<b>12.0 Basic Troubleshooting guide</b> .....	<b>page 18</b>
<b>13.0 General Specifications</b> .....	<b>page 21</b>
<b>14.0 Software Upgrades &amp; Revisions</b> .....	<b>page 22</b>
<b>15.0 Application Notes</b> .....	<b>page 22</b>
<b>16.0 Engine-Protection-Mode wiring diagram</b> ...	<b>page 23</b>
<b>17.0 Typical application wiring</b> .....	<b>page 24</b>
<b>18.0 Rear view and dimensions</b> .....	<b>page 25</b>
<b>19.0 Description of the connections</b> .....	<b>page 26</b>

**Section 1.0 Introduction**

The Be-One is a microcontroller based engine protection module. It provides visual indication by means of LEDs and Display for Fuel Level, Engine & Generator parameters, warnings and shut downs. The Be-One features a set of programmable parameters and complies with SAE regulations. It features 7 modes of operation and provides a serial interface for remote control & monitoring. Figure 1 presents the panel layout.

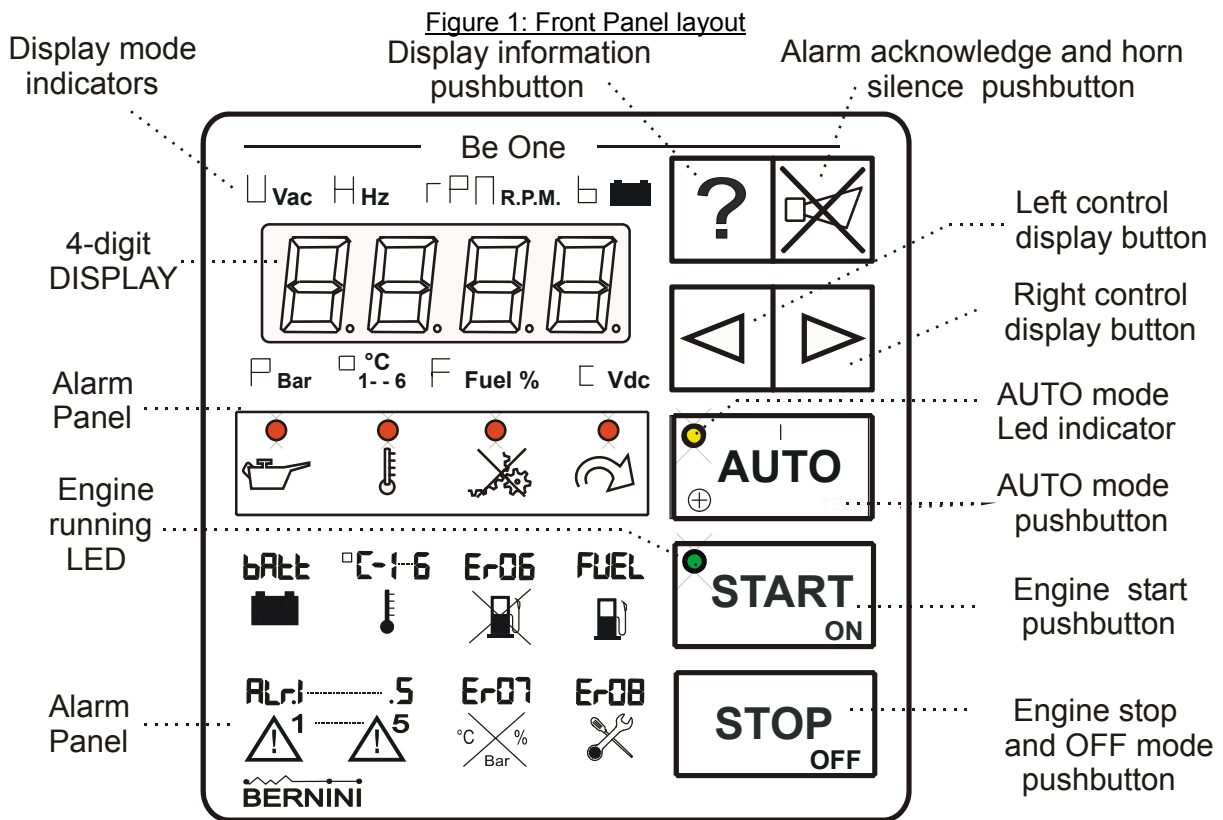

**Section 2.0 Mode selection**

The Modes of operation are selected by pushbuttons. Every time the power supply is switched on, the Be-One returns to the "OFF" mode, unless the Be-One was in TEST or AUTO prior to power down. The following table indicates the available modes.

Mode	Pushbutton	Indication	Section
OFF	[ STOP-OFF ]	All turned Off, dot on display	2.1
MANUAL	[ START-ON ]	The yellow LED AUTO is OFF	2.2
AUTO	[AUTO]	The yellow LED AUTO is ON	2.3
TEST	[AUTO]	The yellow LED AUTO blinks	2.4
PROGRAMMING	see the instructions for the proper use	The display shows <b>[ProG]</b> (the Leds AUTO and START will blink)	6.0
CALIBRATION		The display shows <b>[-CAL]</b> (the Leds AUTO and START will blink)	11.0
TROUBLESHOOTING		See section 12.0	
Engine-Protection Mode		<b>[EPM]</b>	15.20

**2.1 OFF mode**

Push the OFF pushbutton to enter the OFF mode; the Display and LEDs will turn off, a dot on the display will blink slowly and the alarms will be cleared.

**2.2 MANUAL mode**

To start and stop the engine follow the instructions:

**A)** - Push the [START-ON] pushbutton until the display indicates the message [MAN] and all LEDs illuminate; release the button.

**B)** - Push the [ START-ON ] pushbutton until engine starts (\*). When the engine is running, the green LED 'Engine Running' will illuminate (see section10.0).

**C)** - To stop the engine, push the [STOP-OFF ] pushbutton until the [StOP] message appears on the display. If the engine has already stopped, it is possible to cancel the STOP sequence by pressing the [STOP-OFF ] pushbutton. Push [STOP-OFF] when the engine is not running if you want to shutdown the panel.

Note(\*): the display will indicate the message [ . . . ] during the starting attempt and [ ! ! ! ] during the preheat.

**2.3 AUTO mode**

Push [AUTO-TEST] until the yellow LED on the button will illuminate. The engine starts when the Remote Start input activates and stops when the Remote Start input Engine releases. In AUTO mode, the Be-ONE will periodically test the engine if the parameters [P.44] and [P.45] have been programmed. During this test, the yellow LED AUTO will continue to blink. To program an input for Remote Start see 7.07B (option [12]). To program a delay to start and stop the engine see the table 7.00 (parameters [P 0] and [P 1]). Once the Be-One is in AUTO mode, push the [AUTO-TEST] pushbutton for a short time if you want to select the MANUAL mode (see 2,2). In case of Alarms it is not possible to select the AUTO mode.

**2.4 TEST mode**

Enter the AUTO MODE, push and hold for at least 5 seconds (\*), the [AUTO-TEST] pushbutton until the yellow LED will start blinking (the engine will start automatically). To stop the engine, push the [AUTO-TEST] or the [STOP-OFF ] pushbutton.

Note(\*): if you push the button for less than 5 seconds, the Be-one will enter the MANUAL mode

**Section 3.0 Display measurements**

The Be-ONE features a 4 Digit display and 4 pushbuttons as indicated below.

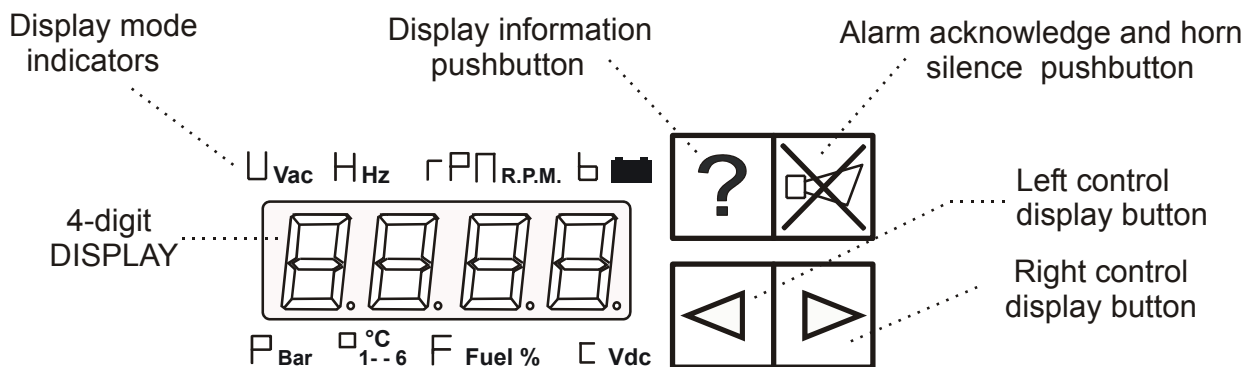

Use [←] and [→] to select a menu. Use [ ? ] to display the name of the parameter. The OFF mode shuts down the display (the dot on the right side will blink). The following table lists the functions of the display.

Display Function	Display indication (*)	Pushbuttons used to select the function	Push [ ? ] to indicate the name of the parameter
Generator Voltage (60 - 600Vac)	[UXXX]	[←] or [→]	[voLt]
Generator Frequency (20 - 70Hz)	[HXX.X]		[HErT]
Speed R.P.M. (10 up to 6000RPM)	[XXXX]		[ rPM]
Battery Voltage Vdc (6-36Vdc)	[bXX.X]		[ bAtt ]
Charger Voltage Vdc (0-36Vdc)	[cXX.X]		[ cHAr]
Oil Pressure Bar (up to 20.0 Bar)	[PXX.X]		[ bAr]
Oil Pressure Bar sensor not used	[P - - -]		[ bAr]
Fuel Level % (0% up to 99%)	[F XX ]		[FUEL]
Fuel Level sensor not used	[F - - -]		[FUEL]
Coolant temperature (0-250 °C) Oil Temperature (0-250 °C) Canopy Temperature (0-250 °C)	[XXX°]		[°C-1] [°C-2] [°C-3]
Coolant temperature not used Oil Temperature not used Canopy Temperature not used	[ t1 - - ] [ t2 - - ] [ t3 - - ]		[°C-1] [°C-2] [°C-3]
Hours-count (0 up to 50.000 h)	[XXXX]		[Hour]

**(\*)NOTE: X indicates a numerical digit, if the measurement is out of range, the display will indicate [ - - - ]**

## **Section 4.0 Display messages**

The Be-One shows alarms (table 4.10) and messages (table 4.20).

***Table 4.10: Alarm messages***

The presence of a warning or shutdown is indicated by the message [Alar.]. Push [→] to browse the message(s). Push [ ? ] to display the parameter. Push [ACK] to acknowledge the alarm (see also sect. 8.0)

Message	Description of the Alarm	Button [ ? ]
[ALAr.]	Indicates the presence of an ALARM. Push [→] to browse the messages (see the list below)	
[OIL.P]	Low Oil Pressure Warning (Sensor)	Bar indication
[Er.01]	Low Oil Pressure Shutdown	
[bELt]	Engine Belt Break Shutdown (It energizes only if the Charger Alternator fails to work and if there is at least one extra-source of Engine running signal; e.g. Pick-upl, Vac or Hz. In case that the Alternator Charger is the only source of signal, the alarm [F.Str] will energize instead of [bELt].)	Vdc indication

Message	Description of the Alarm	Button [ ? ]	
[PicK]	The Be-One detected a failure of the pick-up. The engine shuts down.	None	
[bAtt]	Battery Voltage Warning (High or Low, delayed 180 seconds)	Vdc indication	
[°C-1] [°C-2] [°C-3]	Engine Temperature Switch (Or Sensor) Shutdown Oil Temperature Switch (or Sensor) Shutdown Canopy Temperature Switch (or Sensor) Shutdown	°C indication (if the sensor is not used, the display will indicate the message [S.on])	
[°C-4] [°C-5] [°C-6]	Engine Temperature Warning. Push [?] to display the value. Oil Temperature Warning. Push [?] to display the value. Canopy Temperature Warning. Push [?] to display the value.		
[FUEL] [Er.06]	Fuel level warning (High or Low). Push [?] to display the value. Low Fuel Shutdown (Level switch)		% indication none
[AL. 01]....[AL. 05]	Input #1.....#5 Alarm (Shutdown or Warning)		none
[Er.07]	Failure of a Sensor (Oil pressure, Temperatures or Fuel Level)	[InP1] ..... [InP5]	
[Er.08]	Maintenance Service (when this warning tunes on, you are not allowed to enter the AUTO mode).	-	
[F.StP]	Fail to Stop Alarm	none	
[F.Str]	Fail to Start Alarm	none	
[Err.]	Memory Failure	none	
[ALt]	Alternator Failure	none	
[U.SPd] [O.SPd]	Underspeed (see parameters [P12] and [P13]) Overspeed Shutdown (see parameters [P10] and [P11])	Speed	
[Hi-H] [Lo-H]	Over Frequency Shutdown (see parameters [P6] and [P7]) Under Frequency Shutdown (see parameters [P8] and [P9])	Frequency	
[Hi-U] [Lo-U]	Over Voltage Shutdown (see parameters [P2] and [P3]) Under Voltage Shutdown (see parameters [P4] and [P5])	Volatge ac	

#### 4.20 Miscellaneous messages

Message	Description	Message	Description
[rEst]	The Be-ONE is counting the rest timing	[ProG]	The Be-ONE is in program mode
[. . .]	The Be-ONE is performing the start	[-CAL]	The Be-ONE is in calibration mode
[' ' ']	The Be-ONE is performing the pre-glow	[tEst]	The Be-ONE is in Troubleshooting mode
[StoP]	The Be-ONE is stopping the engine	[ - - - ]	The measurement is out of range
[Err.P]	Wrong programming of a parameter.	[EPM]	Engine Protection Mode
[dEL]	Delay time before cranking	[dIS]	Disable of the Manual mode
[Cool]	It indicates the colling down time	[P0 _][P1 _]	Indicates that the timer P0 (or P1) is counting. The segments of the first digit ( ) illuminates in sequence.

## **Section 5.0 LED indicators**

### **5.1 Lamp and Display Test**

To test the LEDs and DISPLAY, push and hold the [←] and [→] pushbuttons simultaneously (in OFF or MANUAL modes). The LEDs and DISPLAY remain energized as long as the pushbuttons are pressed and held together.

## **Section 6.0 Programming and Reading Parameters**

The display indicates the code of a parameter ([P.0] for example) and its setting ([5"] for example) as explained in section 6.30. Section 7.0 lists all parameters. To enter the Programming Mode, use the following instructions.

### **6.10 Enter the Programming Mode**

- 1) - Provide a voltage battery supply over 7.0V. Push [STOP-OFF] to enter the OFF mode
- 2) - Push and hold the [→] and [ACK] pushbuttons simultaneously, for about 5 seconds, until the message [ProG], appears on the display; the LEDs of the START and AUTO pushbuttons start to blink.
- 3) - If the Be-One is ***password protected*** (Note 1), the messages [PASS] and [4242] will appear in sequence. You are required to follow the instructions of Table 6.11. If the Be-One is ***not password protected*** (Note 2), the programmable parameter [P 0] will be displayed and the Be-One is ready for programming (section 6.12, step-2).

**Note 1: the password consists of 2 groups of digits ranging from 0 to 99. Example: [1234] (12 and 34)**

**Note 2: if you want to protect the programming using a password follow the instructions on section 6.40**

**TABLE 6.11: Enter the PASSWORD**

- 1) - Push [ AUTO-TEST ] or [START] in order to choose the proper code between 00 and 99. Do not select the code [4242] (it indicates no password)
- 2) - Push [←] (or [→]) to select the 2 digits on the right (or left) side.
- 3) - Push [AUTO-TEST] or [START] in order to choose the proper code (between 00 and 99).
- 4) - Push [ACK] to confirm the password; if the password is ok, the Be-One will indicate [P 0] and the unit is ready for programming. If the password is wrong, the display will indicate [4242] and you are required to insert the password again.

*Push [STOP-OFF] at anytime to quit. If you loose the password, the unit shall be returned for service.*

### **6.12 Programming**

- 1) - Enter the Programming mode (see section 6.10).
- 2) - Press the [←] or [→] pushbutton to select a parameter (see the list in section 7.0).
- 3) - To adjust the parameter, press the [ ? ] and [AUTO-TEST] (or [START ] ) simultaneously.
- 4) - Press the [←] or [→] pushbutton to select another parameter.
- 5) - Follow the instructions of section 6.13 or 6.14 according to your needs.

### **6.13 Saving the parameters**

Press and hold the [ACK] and [→] pushbuttons simultaneously until the [SAVE] message will appear (approximately 5 seconds); the Be-One saves the settings and will enter the OFF mode. You can select a mode of operation as indicated in section 2.0.

### **6.14 Exit without Saving the parameters**

Press and hold the [STOP-OFF] pushbutton until the display turns OFF.

### **6.20 Re-programming Default settings**

The parameters of the Be-One are programmed in factory with default settings (section 7.0). To restore them, enter the Programming Mode (section 6.10). When the message [P.0] appears, follow the instructions:

**1)** - Press and hold the [←] and [→] pushbuttons simultaneously, for about 5 seconds, until the display blinks twice. Select the option 2A or 2B according to your needs.

**2A)** - Press and hold the [STOP-OFF] pushbutton until the display turns off (exit the procedure without saving the default parameters).

**2B)** - Press and hold the [ACK] and [→] pushbuttons simultaneously until the [SAVE] message appears (approximately 5 seconds); the Be-One saves the Defaults and it will enter the OFF mode.

### **6.30 Reading the parameters**

To read the setting of the parameters, follow the instructions:

**1)** - Press the [STOP-OFF] pushbutton until the LEDs and display turn OFF.

**2)** - Push the [←] or [→] pushbutton to select a parameter (section 7.0).

**3)** - Push [ ? ] to display the setting of the parameter.

**4)** - Push the [←] or [→] pushbutton to select another parameter.

**NOTE: if the pushbuttons remain inoperative for more than 2 minutes, the Be-One turns off the display.**

### **6.40 Activating the password**

**1)** - Enter the programming mode as indicated in section 6.10.

**2)** - Push the [ACK] pushbutton for about 10 seconds until the display shows [PPPP] and [4242]; release the button. The two digits on the right will blink.

**3)** - Push [AUTO-TEST] or [START] in order to choose a code (avoid the use of the number 42).

**4)** - Push [←] (or [→] ) to select the 2 digits on the left side. Repeat step 3) in order to choose a code

**5)** - If you want to exit the procedure without activating the password, press and hold the [STOP-OFF] pushbutton until the display turns off.

**6)** - Press and hold the [ACK] and [→] pushbuttons simultaneously until the [SAVE] message appears; the Be-One saves the password and remains in PROGRAM mode. To exit, push the [STOP-OFF] pushbutton. You can change the password at anytime as indicated in the section 6.50.

### **6.50 Changing the password**

**1)** - Enter the programming as indicated in section 6.10 and table 6.11. Push and hold the [ACK] pushbutton for about 10 seconds until the message [PPPP] and [4242] will appear. The two digits on the right side of the display will blink.

**2)** - Push [ AUTO-TEST] or [START] in order to choose a code (avoid the use of the number 42).

**3)** - Push [←] to select the 2 digits on the left side. Repeat step 3) in order to choose a code

**4A) - Exit the procedure without changing the old password:** press the [STOP-OFF] pushbutton to exit.

**4B) - Save the password:** press and hold the [ACK] and [→] pushbuttons simultaneously until the [SaVE] message appears (approximately 5 seconds); the GC125A and remains in PROGRAM mode. To exit, push the [STOP-OFF] pushbutton.

### **6.60 Removing the password**

**1)** - Enter the programming mode as indicated in section 6.10 part 3 (you are required to use the old password).

**2)** - When the display indicates a parameter, push and hold the [ACK] pushbutton, for about 10 seconds, until the display will indicate in sequence [PPPP] and [4242]. The code [4242] disables the use of the password.

Follow step 3A of 3B according to your needs.

**3A) - Exit the procedure:** press and hold the [STOP-OFF] pushbutton if you do not want anymore to remove the password.

**3B) - Disables the password:** press and hold the [ACK] and [→] pushbuttons simultaneously until the [SaVE] message appears (approximately 5 seconds); the Be-One saves the code [4242] (it disables the password). The Be-One remains in PROGRAM mode. To exit, push the [STOP-OFF] pushbutton until the display turns off.

## **Section 7.0 Programmable Parameters**

The programmable parameters are divided into classes as indicated below.

7.00 - Remote control	7.07A/B - Programmable inputs
7.01 - Generator Parameters	7.08A/B - Output Programming
7.02A/B - Speed settings	7.09 - Oil Pressure Sensor
7.03 - Engine Control	7.10 - Fuel level Sensor
7.04 - Alarms Options	7.11 - Coolant Temperature Sensor
7.05 - Fuel Alarms	7.12 - Oil Temperature Sensor
7.06 - Miscellaneous	7.13 - Canopy Temperature Sensor

>**Table 7.00 - Remote Start Control** Note: [ xx " ] = seconds, [ xx ' ] = minutes, [xxh ] = hours

<b>P 0</b>	<b>REMOTE START delay timing.</b> Seconds, minutes or hours of continuous REMOTE START command to initiate the automatic engine start.	[ 5" ]	0	23h
<b>P 1</b>	<b>REMOTE STOP delay timing.</b> Seconds, minutes or hours of continuous absence of the REMOTE START command to initiate the stop cycle.	[ 5" ]	0	23h

> **Table 7.01 - Generator Parameters** Note: [ oFF ] = disabled

Parameter Code & Description		Default	Min	Max
<b>P 2</b>	<b>Over Voltage setting</b>	[ OFF ]	60	995
<b>P 3</b>	<b>Over Voltage bypass</b>	[ 1" ]	1"	15"
<b>P 4</b>	<b>Under Voltage setting</b>	[ OFF ]	60	995
<b>P 5</b>	<b>Under Voltage bypass</b>	[ 6" ]	1"	15"
<b>P 6</b>	<b>Over Frequency setting</b>	[ OFF ]	20	70
<b>P 7</b>	<b>Over Frequency bypass</b>	[ 1" ]	1"	15"
<b>P 8</b>	<b>Under Frequency setting</b>	[ OFF ]	20	70
<b>P 9</b>	<b>Under Frequency bypass</b>	[ 6" ]	1"	15"

>Table 7.02 - SPEED SETTINGS Note: [ xx " ] = seconds, [ xx ' ] = minutes, [ oFF ] = disabled

Parameter Code & Description		Default	Min	Max	Options
P 10	Over Speed	[oFF]	100	4000	[oFF]
P 11	Over Speed delay	[ 1" ]	1sec	15secs	-
P 12	Under Speed	[oFF]	100	4000	[oFF]
P 13	Under Speed delay	[ 6" ]	1sec	15secs	-
P 14	Number of the Teeth of the flywhell	[oFF]	0.1	500.0	[oFF]
P 15	Number of Poles of the alternator Options [2] or [4] allow you to display the speed if the teeth number is [oFF].	[oFF]	2	4	[oFF]

>Table 7.03A - ENGINE CONTROL Note: [ xx " ] = seconds, [ xx ' ] = minutes, [ oFF ] = disabled

P 16	Crank delay after Fuel Solenoid activation	[ 2" ]	0	15secs	-
P 17	Crank timing	[ 5" ]	1 sec.	15secs	-
P 18	Rest timing	[ 5" ]	3secs	15secs	-
P 19	Starting attempts (numbers)	[ 3 ]	1	15	-
P 20	Purge timing (for Gas fuelled engine)	[ 1" ]	1sec	15secs	-

>Table 7.03B - ENGINE CONTROL Note: [ xx " ] = seconds, [ xx ' ] = minutes, [ oFF ] = disabled

Parameter Code & Description	Default	Min	Max	Options	
P 21	Pre-glow time	[ oFF ]	1sec	59mins	[ oFF ]
P 22	Pre-glow time Modes (see below)	[ 1 ]	-	-	1-2-3-4

The diagram illustrates the timing sequence for engine starting. It shows the following components and their durations:

- Starting Motor:** A pulse that occurs at the beginning of the sequence.
- Total rest timing:** A period of inactivity following the starting motor pulse, controlled by parameter [ P.20 ].
- Pre-glow mode 1:** A pulse occurring during the rest timing, controlled by parameter [ P.22 ].
- Pre-glow mode 2:** A pulse occurring during the rest timing, controlled by parameter [ P.22 ].
- Pre-glow mode 3:** A pulse occurring during the rest timing, controlled by parameter [ P.21 ].
- Pre-glow mode 4 (Choke):** A pulse occurring during the rest timing, controlled by parameter [ P.22 ].
- Crank termination (engine running detect):** A signal that terminates the sequence once the engine is running, controlled by parameters [ P.26 ]..[ P.27 ]..[ P.28 ].

**>Table 7.03C - ENGINE CONTROL** Note: [ xx " ] = seconds, [ xx ' ] = minutes, [ oFF ] = disabled

Parameter Code & Description		Default	Min	Max	Options
<b>P 23</b>	Stop Solenoid timing	[ 15" ]	1sec	59mins	-
<b>P 24</b>	Crank termination (Charger Alternator)	[ 8.0 ]	3.0V	30.0V	[oFF]
<b>P 25</b>	Belt break setting (Charger Alternator)	[ 8.0 ]	3.0V	30.0V	[oFF]
<b>P 26</b>	Crank termination (RPM SPEED)	[300]	100	800	[oFF]
<b>P 27</b>	Engine Warm up timing	[15"]	0	59mins	-
<b>P 28</b>	Engine cool down timing	[15"]	0	59mins	-
<b>P 29</b>	Low Oil pressure Warning	[oFF]	0.1Bar	20.0 Bar	[oFF]
<b>P 30</b>	Low Oil pressure Shutdown	[oFF]	0.1Bar	20.0 Bar	[oFF]
<b>P 31</b>	Engine Temperature Warning	[oFF]	40°C	250°C	[oFF]
<b>P 32</b>	Engine temperature Shutdown	[oFF]	40°C	250°C	[oFF]
<b>P 33</b>	Oil temperature Warning	[oFF]	40°C	250°C	[oFF]
<b>P 34</b>	Oil temperature Shutdown	[oFF]	40°C	250°C	[oFF]
<b>P 35</b>	Canopy temperature Warning	[oFF]	40°C	250°C	[oFF]
<b>P 36</b>	Canopy temperature Shutdown	[oFF]	40°C	250°C	[oFF]

**>Table 7.04 - ALARM OPTIONS** Note: [ xx " ] = seconds, [ xx ' ] = minutes, [ oFF ] = disabled

Parameter Code & Description		Default	Min	Max	Options
<b>P 37</b>	Engine Alarms bypass (for Oil, Temperature and Auxiliary alarms)	[ 5" ]	2secs	90secs	-
<b>P 38</b>	Fail to stop alarm control (off = inhibited, on = enabled)	[oFF]	-	-	[oFF]/ [on]
<b>P 39</b>	Horn timeout (see section 8.0)	[ 5" ]	5secs	15mins	[oFF]

**>Table 7.05 - FUEL ALARMS OPTIONS** Note: [ xx " ] = seconds, [ xx ' ] = minutes, [ oFF ] = disabled

Parameter Code & Description		Default	Min	Max	Options
<b>P 40</b>	Fuel RESERVE. (Switch or sensor). The option OFF disables the reserve bypass; the engine will shutdown immediately.	[ 5' ]	15secs	99mins	[oFF]
<b>P 41</b>	Low Fuel % shutdown	[oFF]	1%	99%	[oFF]
<b>P 42</b>	Low Fuel % (warning only)	[oFF]	1%	99%	[oFF]
<b>P 43</b>	High Fuel % (warning only)	[oFF]	1%	99%	[oFF]

>Table 7.06 - MISCELLANEOUS

Note: [ xx " ] = seconds, [ xx ' ] = minutes, [ oFF ] = disabled

Parameter Code & Description		Default	Min	Max	Options
<b>P 44</b>	Periodic Test interval	[oFF]	1 Day	60 Days	[oFF]
<b>P 45</b>	Periodic Test duration	[ 5' ]	1 min	99 mins	-
<b>P 46</b>	Maintenance SERVICE	[oFF]	1h	9999h	[oFF]
<b>P 47</b>	RS485 Node Address	[ 1 ]	1	127	-
<b>P 48</b>	Hour Counter set (over 9999, a dot will appear to indicate a value multiplied by10. Example [3250.] means 32500 hours. The display will indicate steps of 10 hours)	[ 0 ]	0h	50.000 (the display indicates [5000.] )	-

>Table 7.07A - Input programming

Parameter Code & Description		Default	Parameter Code & Description		Default
[Inp 1]	Input 1	[ 1 ]	[Inp 4]	Input 4	[ 12 ]
[Pol 1]	Input mode (n.c.-n.o. -Sensor)	[n.c.]	[Pol 4]	Input mode (n.c.-n.o. -Sensor)	[n.o.]
[Inp 2]	Input 2	[ 2 ]	[Inp 5]	Input 5	[ 6 ]
[Pol 2]	Input mode (n.c.-n.o. -Sensor)	[n.o.]	[Pol 5]	Input mode (n.c.-n.o. -Sensor)	[n.c.]
[Inp 3]	Input 3	[ 3 ]	NOTE: when a Sensor mode ([SEnS]) is selected, you are allowed to use only the options [1]-[2]-[3]-[4]-[5] (see table 7.07B).		
[Pol 3]	Input mode (n.c.-n.o. -Sensor)	[n.o.]			

>Table 7.07B - Input Options List

Option	Description	Option	Description
[ OFF ]	Not used	[ 8 ]	Cooling and Stop
[ 1 ]	Oil pressure (Switch or Sensor)	[ 9 ]	Bypass+Cooling and Stop
[ 2 ]	Fuel Level (Switch or Sensor)	[ 10 ]	Warning
[ 3 ]	Coolant Temperature (Switch or Sensor)	[ 11 ]	Warning with auto reset
[ 4 ]	Oil Temperature (Switch or Sensor)	[ 12 ]	Remote Start
[ 5 ]	Canopy Temperature (Switch or Sensor)	[ 13 ]	Horn Silence
[ 6 ]	Emergency Stop	[ 14 ]	Disable of manual mode
[ 7 ]	Bypass and Stop	[ 15 ]	Engine-Protection-Mode

> Table 7.08A - Output programming

Option	Factory setting	Available options (see 7.08B)
[Out1]	[ 1 ] Fuel Solenoid (energized to run)	[ OFF ] [ 1 ] - [ 31 ]
[Out2]	[ 2 ] Start Solenoid (energized to start)	[ OFF ] [ 1 ] - [ 31 ]
[Out3]	[ 3 ] Pre-glow	[ OFF ] [ 1 ] - [ 31 ]
[Out4]	[ 4 ] Horn (common alarm output)	[ OFF ] [ 1 ] - [ 31 ]

> **Table 7.08B - Output Options Table: [Option] & description**

[ OFF ]	Output not active	[16]	Engine Belt Break Shutdown
[ 1 ]	Fuel Solenoid	[17]	Maintenance Service Timeout
[ 2 ]	Start Solenoid	[18]	Fail To START Shutdown
[ 3 ]	Pre-glow (glow -plugs)	[19]	Fail To STOP Shutdown
[ 4 ]	Alarm (Horn)	[20]	P.0 timing (delay to start the engine)
[ 5 ]	Stop Solenoid	[21]	P.1 timing (delay to stop the engine)
[ 6 ]	Contactors of the Generator (KG)	[22]	Be-One in OFF MODE (Status)
[ 7 ]	Engine Running Status	[23]	Be-One in MANUAL MODE (Status)
[ 8 ]	PURGE (gas engine valve control)	[24]	Be-One in AUTO MODE (Status)
[ 9 ]	Under-Over Speed Shutdown	[25]	Be-One in TEST MODE (Status)
[10]	Oil Pressure Alarm or Sensor failure	[26]	Engine Protection Mode
[11]	Temperature Alarm or Sensor failure	[27]	Automatic Periodic Test
[12]	Fuel Level Alarm or Sensor failure	[28]	Warm UP timing
[13]	Shutdown Alarm 1/2/3/4	[29]	Cooling down timing
[14]	Warning Alarm 1/2/3/4	[30]	Over-Under Voltage Shutdown
[15]	Battery Voltage alarm (High or Low)	[31]	Over-Under Frequency Shutdown

> **Table 7.09 - Oil Pressure Sensor Settings (Note^)**

Display	Parameter	Default	Range
[ Pr1 ]	Pressure	[ 0.0 ] Bar	0 up to 20 Bar 0 up to 2000 Ohm
[-r1-]	Resistance	[ 10 ] Ohm	
[ Pr.2 ]	Pressure	[ 2.0 ] Bar	
[-r2-]	Resistance	[ 51 ] Ohm	
[ Pr.3 ]	Pressure	[ 4.0 ] Bar	
[-r3-]	Resistance	[ 86 ] Ohm	
[ Pr.4 ]	Pressure	[ 6.0 ] Bar	
[-r4-]	Resistance	[ 122 ] Ohm	
[ Pr.5 ]	Pressure	[ 8.0 ] Bar	
[-r5-]	Resistance	[ 152 ] Ohm	
[ Pr.6 ]	Pressure	[ 10.0 ] Bar	
[-r6-]	Resistance	[ 180 ] Ohm	

> **Table 7.10 - Fuel Level Sensor (Note^)** 7.11

> **Table Coolant Temperature Sensor (Note^)**

Display	Parameter	Default	Range	Display	Parameter	Default	Range
[FUE1]	Fuel Level	[ 0 ]	1% up to 99% 0 Ohm up to 2000 Ohm	[°C1.1]	Temperature	[ 128 ]	0°C up to 250°C 0 Ohm up to 2000 Ohm
[-r1-]	Resistance	[ 10 ]		[-r1-]	Resistance	[ 19 ]	
[FUE2]	Fuel Level	[ 0 ]		[°C1.2]	Temperature	[ 115 ]	
[-r2-]	Resistance	[ 10 ]		[-r2-]	Resistance	[ 26 ]	
[FUE3]	Fuel Level	[ 0 ]		[°C1.3]	Temperature	[ 90 ]	
[-r3-]	Resistance	[ 10 ]		[-r3-]	Resistance	[ 46 ]	
[FUE4]	Fuel Level	[ 0 ]		[°C 4]	Temperature	[ 80 ]	
[-r4-]	Resistance	[ 10 ]		[-r4-]	Resistance	[ 67 ]	
[FUE5]	Fuel Level	[ 50 ]		[°C 5]	Temperature	[ 70 ]	
[-r5-]	Resistance	[ 95 ]		[-r5-]	Resistance	[ 95 ]	
[FUE6]	Fuel Level	[ 99 ]		[°C 6]	Temperature	[ 40 ]	
[-r6-]	Resistance	[ 180 ]		[-r6-]	Resistance	[ 287 ]	

> **TABLE 7.12 - Oil Temperature Sensor (Note<sup>^</sup>)** > **TABLE 7.13 - Canopy Temperature Sensor (Note<sup>^</sup>)**

Display	Parameter	Default	Range	Display	Parameter	Default	Range
[°C2.1]	Temperature	[ 128]	0°C up to 250°C 0 Ohm up to 2000 Ohm	[°C3.1]	Temperature	[ 128]	0°C up to 250°C 0 Ohm up to 2000 Ohm
[-r1-]	Resistance	[ 19 ]		[-r1-]	Resistance	[ 19 ]	
[°C2.2]	Temperature	[ 115]		[°C3.2]	Temperature	[ 115]	
[-r2-]	Resistance	[ 26]		[-r2-]	Resistance	[ 26]	
[°C2.3]	Temperature	[ 90]		[°C3.3]	Temperature	[ 90]	
[-r3-]	Resistance	[ 46]		[-r3-]	Resistance	[ 46]	
[°C2.4]	Temperature	[ 80]		[°C3.4]	Temperature	[ 80]	
[-r4-]	Resistance	[ 67]		[-r4-]	Resistance	[ 67]	
[°C2.5]	Temperature	[ 70]		[°C3.5]	Temperature	[ 70]	
[-r5-]	Resistance	[ 95]		[-r5-]	Resistance	[ 95]	
[°C2.6]	Temperature	[ 40]		[°C3.6]	Temperature	[ 40]	
[-r6-]	Resistance	[ 287]		[-r6-]	Resistance	[ 287]	

*Note<sup>^</sup>: the resistance values can be set upward or downward; use different settings for each point of the table*

## **Section 8.0 - Alarms, Warnings and Shutdowns**

The Be-ONE features Shutdowns (the engine stops) and Warnings (the engine will continue to run) and provides:

- A) - a general indication of alarm presence by means of the message [ALAr.] on the display
- B) - 4 configurable outputs with several options for each (see 7.08A-B)
- C) - 4 LEDs to indicate: Oil pressure, Temperature, Fail to start and Over speed shutdown.
- D) - display messages indicating warnings and shutdowns (see Table 4.1)
- E) - an [ACK] pushbutton to silence the Horn

To silence the HORN, push the [ACK] pushbutton or wait for the [P39] to expire (see section 7.04). If the [P39] is set to [OFF], the only way to silence the Horn is by means of the [ACK] pushbutton.

To browse the alarm memory push the [→] pushbutton. In order to display the details of the alarm, push the [ ? ] pushbutton. To clear the alarm from the panel, remove the cause of the alarm and then press the [STOP-OFF] pushbutton. The table 4.10 in the section 4.0 indicates all alarms.

## **Section 8.1 – Event History**

The Be-ONE features an Event History register able to records the last 100 shut-downs. To read the contents of the Event History, follow the instructions:

- A) – Remove the DC power supply (battery voltage)      B) – Push and hold the [?] pushbutton
- C) – Apply the power supply (holding the [?] pushbutton)
- D) – Release the [?] pushbutton when the display turns on
- E) – The display will indicate the address of the last event ([E 01]). Push the the [?] pushbutton to display the name of the Event (see table 4.10)
- F) – You can select an event from [E 01] to [E100] using the [←] and [→] pushbuttons. [E100] indicates the oldest event. [E01] indicates the latest one.
- G) – To display the code of the Event, push the [?] pushbutton (see table 4.10).

It is not possible to cancel the Event History.

## **Section 9.0 Hour Meter**

To clear or pre-load the counter, use the following instructions:

- 1) - Enter the programming mode as indicated in the section 6.10 & 6.20
- 2) - Select the parameter [P48] by means of the [←] or [→] pushbutton.
- 3) - Press the [ ? ] and [ START ] (or [ AUTO ]) pushbuttons simultaneously to set a value. If you set [0], you will cancel the [h-counter]. If you set a value between 1 to 50000, you will pre-set the counter.

Follows steps 4A) or 4B) according to your needs.

- 4A)** - Press and hold the [ACK] and [→] pushbuttons simultaneously until the [SaVE] message appears (for about 5 seconds); the Be-ONE saves the hour counter in the memory and will enter the OFF mode.
- 4B)** - Press the [STOP-OFF] pushbutton to exit the procedure without modifying the counter.

## **Section 10.0 Engine Running Detect (Charger Alternator)**

The Be-One inhibits the starter motor when the engine starts running. When the engine is not running, the voltage of the terminal D+/WL of the charger alternator is 0V. As soon as the Be-One starts the engine, a voltage appears in the D+/WL terminal (0,8 to 2,5V). When the engine starts running, the voltage of the D+/WL terminal increases by up to 3V-6V. When the engine runs, the voltage reaches 14V (28V) needed to charge the battery. The safest point to disconnect the starter motor is between 6V to 10V. The default parameter of [P24] is 8.0V. This value is recommended for engines using 12V batteries. For 24V batteries, we recommend that you set the threshold to 16V.

For a safe calibration, be sure that the green 'ENGINE RUNNING' LED on the front panel is off during all of the starting attempts. The Charger Alternator voltage can be displayed as indicated in the section 3.0. For Flywheel chargers, the reading is not accurate. The [P24] setting, in this case, expresses only a proportional factor.

The Be-One also uses the Speed measurement to disconnect the crank motor. The parameter [P26] sets the crank termination.

**NOTE: THE 'ENGINE RUNNING' LED MUST BE LIT WHEN THE ENGINE RUNS. USING THE ENGINE WITHOUT THIS SIGNAL MAY BE DANGEROUS.**

Normally, using a diesel engine, we recommend enabling the BELT BREAK protection. This is accomplished by programming a voltage setting in the [P25]. To test the efficiency of the protection, disconnect the terminal D+ from the charger alternator and connect to ground the RUN+ terminal. This protection is delayed by 20 seconds.

## **Section 11.0 - Calibration and Memory Reset**

**11.1 - Enter the calibration** To enter the calibration follow the instructions.

- 1) - Make sure the Battery voltage is over 7,0Vdc and select the MAN mode. Start the engine
- 2) - Push and hold the [←] and [ACK] pushbuttons simultaneously, for about 5 seconds, until the message [-CAL] appears; release the buttons.
- 3) - If the Be-ONE programming is password protected, the message [4242] will appear; follow the instructions on the table 6.11. If the Be-ONE is not password protected, the parameter [voLt] will appear on the display and you can proceed as indicated in the section 11.2.

**11.2 - Calibrating a measurement** (Note: to exit the procedure, push the[STOP-OFF] pushbutton at anytime)

- 1) - Press the [←] or [→] pushbutton to select a 'Parameter' (see Table 11.2). Start the engine if necessary.
- 2) - Press the [ ? ] pushbutton to display the reading of the measurement.
- 3) - Press the [AUTO] (or [START] ) to adjust the reading according to an external reference.
- 4) - When finished, push the [ ? ] again to display the 'Parameter'. Select another 'Parameter' to calibrate by pushing the [←] or [→] pushbutton. Choose the option 5A, 5B or 5C.
- 5 A ) - Exit the procedure without saving by pushing the [STOP-OFF] pushbutton.
- 5 B ) - Restore the factory original calibration: press and hold the [←] and [→] pushbuttons simultaneously until the display will blink twice. You are required to save the setting as indicated in step 5C.
- 5 C ) - Save the calibration: push and hold the [ACK] and [→] pushbuttons simultaneously until the [SaVE] message appears (approximately 5 seconds); the Be-ONE saves the calibrations, and will enter the MANUAL mode.

**Table 11-2, List of the Measurements in Calibration Mode**

'Parameter'	Description	Unit	Recommended Calibration Range
[voLt]	Voltage of the generator	Volt	200 up to 400 Vac
[HErt]	Frequency of the generator	Hertz	40 up to 60Hz
[rPM]	Speed of the engine	R.P.M.	1400 up to 2000 R.P.M.
[bAtt]	Battery voltage	Vdc	12 up to 27 Vdc
[bAr]	Oil Pressure	Bar	2 Bar up to 4 Bar
[FUEL]	Fuel Level	%	80% - 90%
[°C-1] [°C-2] [°C-3]	Coolant Temperature Oil Temperature Canopy Temperature	°C	80°C up to 100°C
[MEM]	Memory initialization	-	-

### **11.3 - Memory Reset**

- Stop the engine if running
- Enter the calibration as explained in section 11.1
- Select the message **[MEM]** on the display, push and hold the [ACK] pushbutton (for about 30 seconds) until the message [Init] appears. The Be-One downloads the default settings (see section 7.0), clears the hour-count, restores the factory calibrations and will enter the MANUAL mode.

## Section 12.0 Basic Troubleshooting Guide

The Basic Troubleshooting Guide provides you a guide to solve problems that you may experience with the Be-One. We recommend that you disconnect the unit from the panel and set up the troubleshooting application circuit as indicated in section 12.1. This procedure must be carried out by qualified personnel only.

**! WARNING !** High voltage is present inside this instrument. To avoid electric-shock hazard, operating personnel must not remove the protective cover. Do not disconnect the grounding connection. Any interruption of the grounding connection can create an electric shock hazard. Before making external connections, always ground the Be-One first by connecting the control panel to ground.

### Section 12.1 Troubleshooting wiring diagram

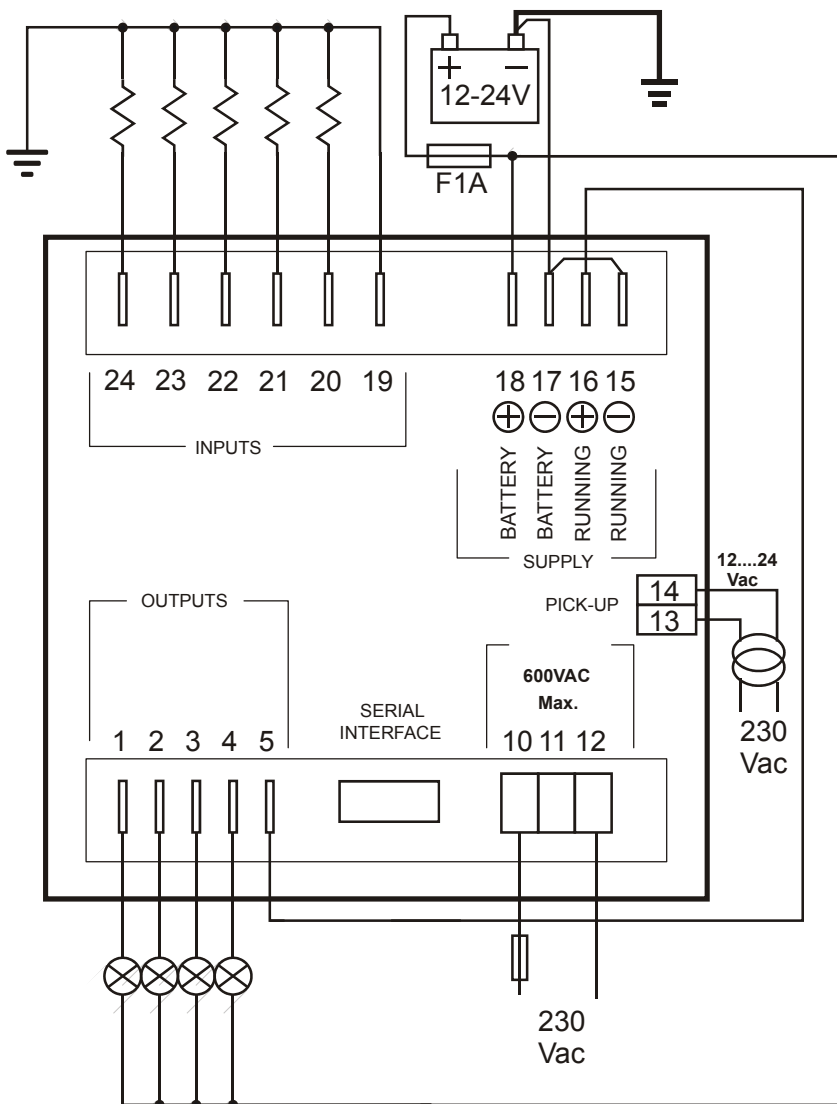

- A) - Remove the battery power supply; disconnect all connectors and terminals
- B) - Push and hold the [ACK] pushbutton, apply the Vdc power supply; all LEDs and Display turn on.
- C) - Release the button after the verification of all indicators; the LEDs will turn off and the message [- in -] will be displayed. If the message [Gnd] will appear, you are required to connect the terminal #19.

**NOTE - At this stage of the TEST, if the display indicates one of the codes contained in Table 12.1 or 12.2, the Be-One is damaged and should be returned for service.**

### **12.1 Testing the Inputs**

- D) - Connect the terminal #19 to ground.
- E) - Connect, one by one, to the battery minus, the inputs #20 to #24 . For each input, a code will be displayed according to Table 12.1. If more than one input is connected (if in short circuit for example), the display indicates the messages in sequence.

**Table 12.1**

Terminal number (function)	Display Code	NOTE
#24 (Input 5)	[ inP 5]	If the message [ Gnd ] appears, you are required to connect the terminal #19 to ground.
#23 (Input 4)	[ inP 4]	
#22 (Input 3)	[ inP 3]	
#21 (Input 2)	[ inP 2]	
#20 (Input 1)	[ inP 1]	

### **12.2 Testing the Pushbuttons**

- A) - Push the pushbuttons [ACK] pushbutton until the message [butt] will appear.
- A) - Push the pushbuttons on the front panel one by one. The display will show a message according to Table 12.2. As soon as you release all buttons, the message [butt] will be displayed.

**Table 12.2: Pushbuttons true table**

Pushbutton	Display Code
[ACK]	[ ACK ]
[ ? ]	[ ? ]
[←]	[ LEfT ]
[→]	[ rIGH ]
[AUTO-TEST]	[ Auto ]
[START-ON]	[ StAr ]
[STOP-OFF]	[ StoP ]

### **12.3 Testing the Outputs**

- A) - Push the [ACK] pushbutton, for about 10 seconds, until the message [-out ] appears.

**B)** - Plug the terminals #1 - #4, as indicated in the **Table 12.1**. At this stage, if a lamp turns on, the Be-One is damaged and should be returned for service.

**C)** - Push a button on the front panel. According to **Table 12.3**, the display should indicate the proper message and the lamp turns on. If a lamp fails to turn on, the Be-One is damaged and should be returned for service.

**Table 12.3: Outputs true table**

Pushbutton	Terminal Output	Display Code	NOTE
[STOP-OFF]	# 1	[out1]	Activates the output 1
[START-ON]	# 2	[out2]	Activates the output 2
[AUTO-TEST]	# 3	[out3]	Activates the output 3
[→]	# 4	[out4]	Activates the output 4

#### **12.4 Testing the Sensors**

**A)** - Push the [ACK] pushbutton for about 3 seconds until the message [SEnS] appears.

**B)** - Apply 5 resistors of known value (+/- 1%) in a range 100 Ohm up to 1000 Ohm as indicated in **Table 12.1**.

**C)** - Push the pushbuttons according to the Table 12.4. The display will indicate the value in OHM as long as you push and hold the button. If the indication is 3% or over (that the expected value), the Be-One is damaged and should be returned for service.

**Table 12.4: Sensor true table**

Pushbutton	Display indication (°)	Terminal number	Function	Note
[STOP-OFF]	[XXXX]	# 20	Configurable Sensor	Recommended resistor range (+/-1%) 100-1000 Ohm
[START-ON]	[XXXX]	# 21		
[AUTO-TEST]	[XXXX]	# 22		
[→]	[XXXX]	# 23		
[←]	[XXXX]	# 24		

(°)Note. [XXXX] indicates a 4 digit number. In case the input is open, the display will indicate 2500

#### **12.5 Testing the Pick-up and Measurements**

**A)** - Push the [ACK] pushbutton for about 3 seconds until the message [MEAS] appears.

**Table 12.5: Table of the Measurements**

Pushbutton	Display indication (°)	Terminal number	Function	Note
[STOP]	[UXXX]	10, 12	Generator Voltage	-
[START]	[HXX.X]	10, 12	Frequency Voltage	-
[AUTO]	[XXXX]	13, 14	Frequency of the Pick-up input	Number of the teeth set to 60 automatically
[→]	[cXX.X]	15, 16	Charger alternator voltage	-
[←]	[XXXX]	17, 18	Battery Voltage	-

(°)Note. [XXXX] indicates a 4 digit number. In case the input is open, the display will indicate 9999

### **Section 13.0 General Specifications**

**Supply Voltage** [\*\*\*]: 5.5Vdc to 36Vdc. **Supply Current:** 50 mA up to 100mA  
**Dimensions:** 96mm X 96mm X 47mm, **Panel Cut-out:** 91mm X 91mm, indoor operation  
**Operating Temperature range:** -25 deg C up to +70 deg C. **Humidity Range:** 5% up to 95% non-condensing.  
**Weight:** 250 gr., **Vibration:** 40mm/sec

**General Design:** 89/336 EEC, 89/392 EEC, 73/23 EEC, 93/68 EEC, IEC 68-2-6 **Certification:** CE

**Static Outputs:** Output Current: 300mA/100Vdc (internal AUTO-reset 700mA Fuse is provided). Logic: negative.

**Pick-up Input:** Voltage input: 2 - 60Vac. Max Frequency: 10KHz

**Digital Inputs** Open circuit V: 10Vdc (12V supply) or 22Vdc (24V supply) - Closed circuit current: 15mAdc maximum.

**Charger Alternator Monitoring:** Operating Voltage up to 36Vdc. Vdc reading accuracy +/- 5%. Excitation Power: max 3W

**Generator Monitoring:** Operating Voltage up to 600Vac. Vac reading accuracy +/- 1,5%. frequency: 20-70Hz [\*\*]

[\*] **NOTE:** the sum of the total output current may not exceed 2A at 70°C

[\*\*] **NOTE:** errors can be reduced by using the calibration (section 11.0)

[\*\*\*] **NOTE:** operations with memory (storing parameters, hours, etc) are allowed only if the Vdc is over 7.0V.

## **Section 14.0 Software Upgrades & Revisions**

Software Versions	Date	User manual	Description
V.1.60	20-January- 09	V.16X	Implementation teeth in step of 0,1
V.1.61/62	05-February- 09	V.16X	Crank termination filtering, Under V / Under Hz work in Manual mode
V.1.64	05-February- 09	V.16X	Indication of the Speed measurement have been improved
V.1.65	03-November- 09	V.165	Improved the performance of the troubleshooting procedure

User Manual upgrade	Date	Description
V.15X	05-August-08	Implementation of the EVENT HISTORY
V.16X	20-January-08	Implementation teeth in step of 0,1
V.165	03-November-09	Extended to 3 year the warranty period

## **Section 15.0 Application Notes**

**15.10 - Automatic Periodic Test (hereinafter A.P.T)** The Be-One does not use a real time clock to count the programmed days ([P44] setting, table 7.06). The user could experiment with shifting the periodic tests. To avoid error accumulation, we recommend the following procedures.

### **15.11 - First time programming of the A.P.T. (example: 20 minutes every 7 days)**

**A)** - Enter the 'Program Mode' and set [P44] to [ 7 ] days. **B)** - Set [P45] to [ 20' ] and save the programming  
**C)** - Follows the instructions of the section 15.12

### **15.12 - Adjusting the starting moment**

**A)** - Disconnect the battery and wait for the desired start time (using an external clock reference).  
**B)** - Connect the battery and select the 'AUTO' mode.

The Be-One will start the engine after the programmed days. The engine will run for 20 minutes.

***IMPORTANT NOTICE*** If the Vdc supply is removed, the Be-One loses the counts of the days. If the supply restores, the Be-One starts to count the days from zero. To synchronize the periodic start, follow the instruction of the section 15.12.

### 15.20 - Interfacing Be-One with other Controller (Engine - Protection - Mode)

The Be-one can be used as a redundant protection providing more safety for the engine. In this case an external module will start the engine. In case of failure, the BE-ONE will shut down the engine.

For this application, use the wiring diagram of the section 16.0 and follow the instructions:

- Select the option **[15] [n.c.]** for the input 1 and connect to ground.
- When the engine starts to run, the Be-One will monitor the alarms. The **[START]** , **[ AUTO ]** and **[ OFF ]** pushbuttons on the BE-ONE front panel will be ignored.
- In case of alarm, the Be-One will shut down the engine (or activates only the horn in case of a warning).
- Push **[ACK]** to silence the horn and the buttons **[→]** **[←]** **[ ? ]** to find out details about the alarm.
- In order to cancel the alarm push the **[ OFF ]** pushbutton or switch the EPM mode input.

### Section 16.0 Engine - protection - mode (E.P.M.) wiring diagram

<b>Programming</b>	
Parameter	Description
[Out1][ 1 ]	Output 1 in Stop solenoid mode
[Out4][ 4 ]	Output 4 in Horn output mode
[Inp 1][ n.c. ]	Input 1 in normally closed mode
[Inp 1][ 15 ]	Input 1 in EPM input mode

<b>Nomenclature</b>	
Name	Description
K1	Stop Relay (always active)
K2	Alarm Relay (always active)
Engine Sensors	Sensors or Switches for engine protection

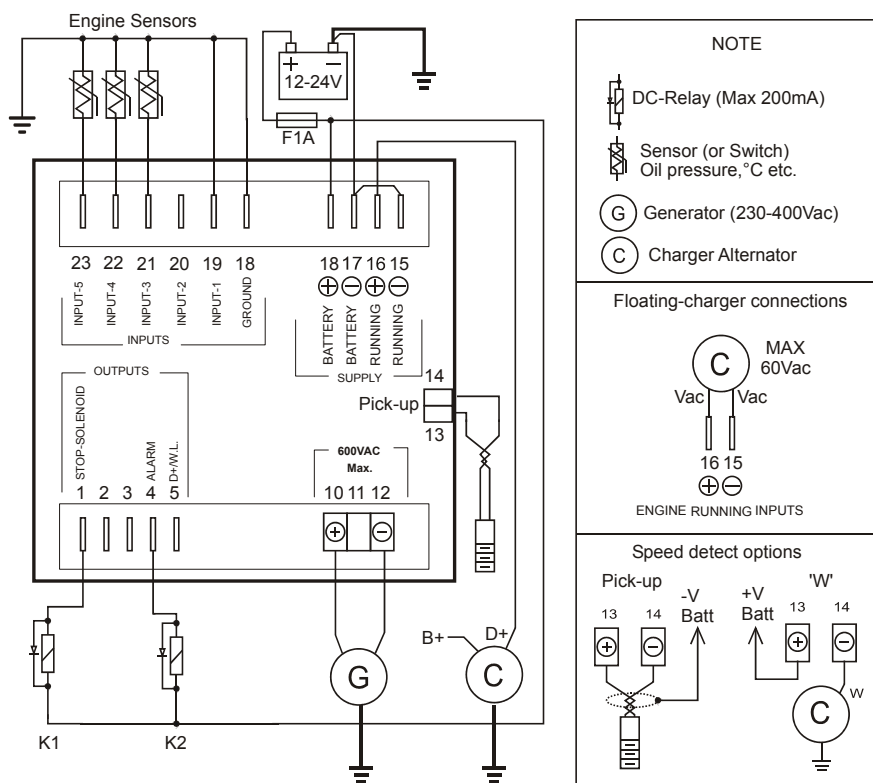

17.00 - Typical application wiring diagram

**!! WARNING !! Relays and solenoids connected to the Be-One must be suppressed using flywell diodes or suppression devices as indicated below**

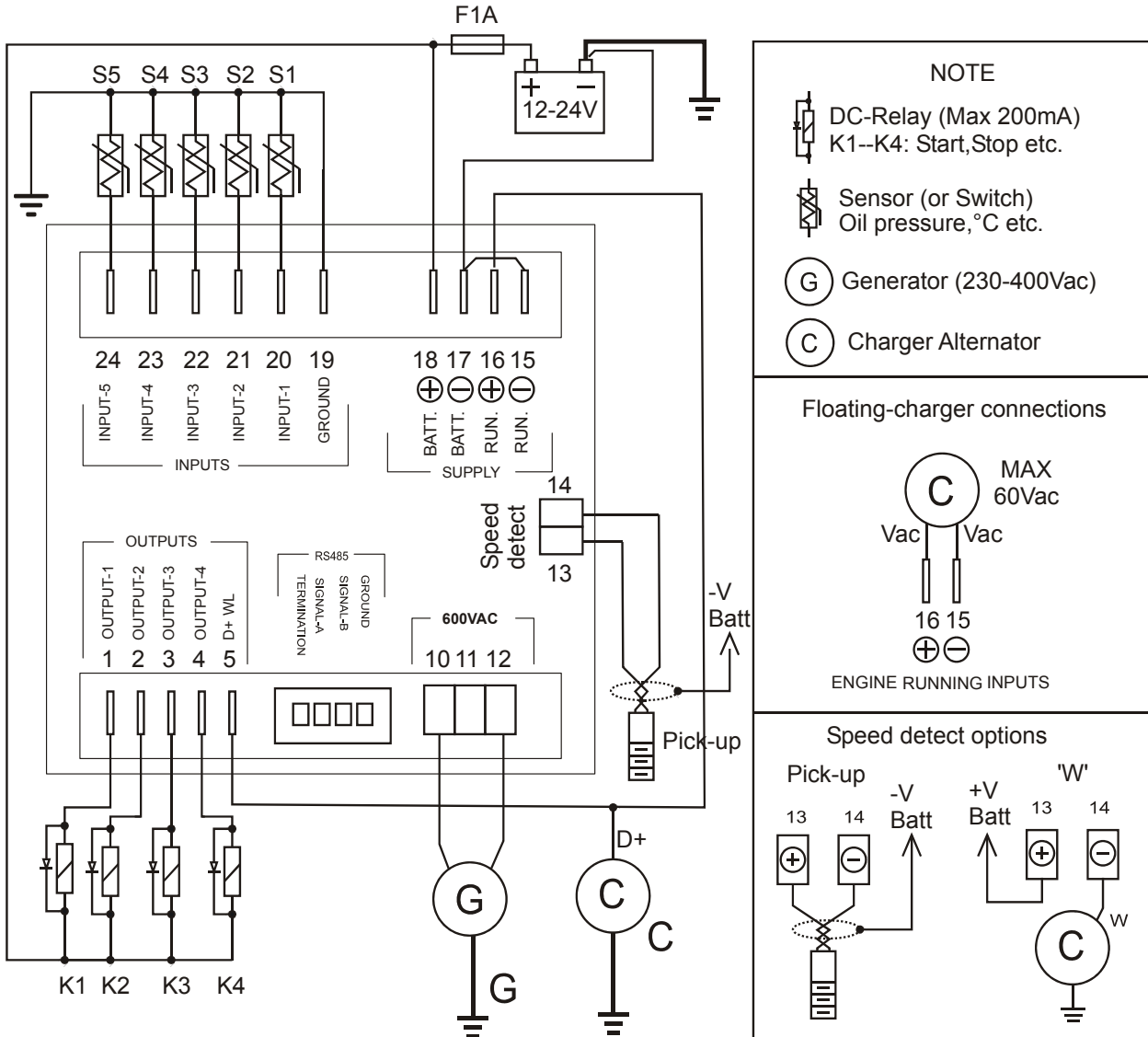

**Section 18.0: Rear view and dimensions**

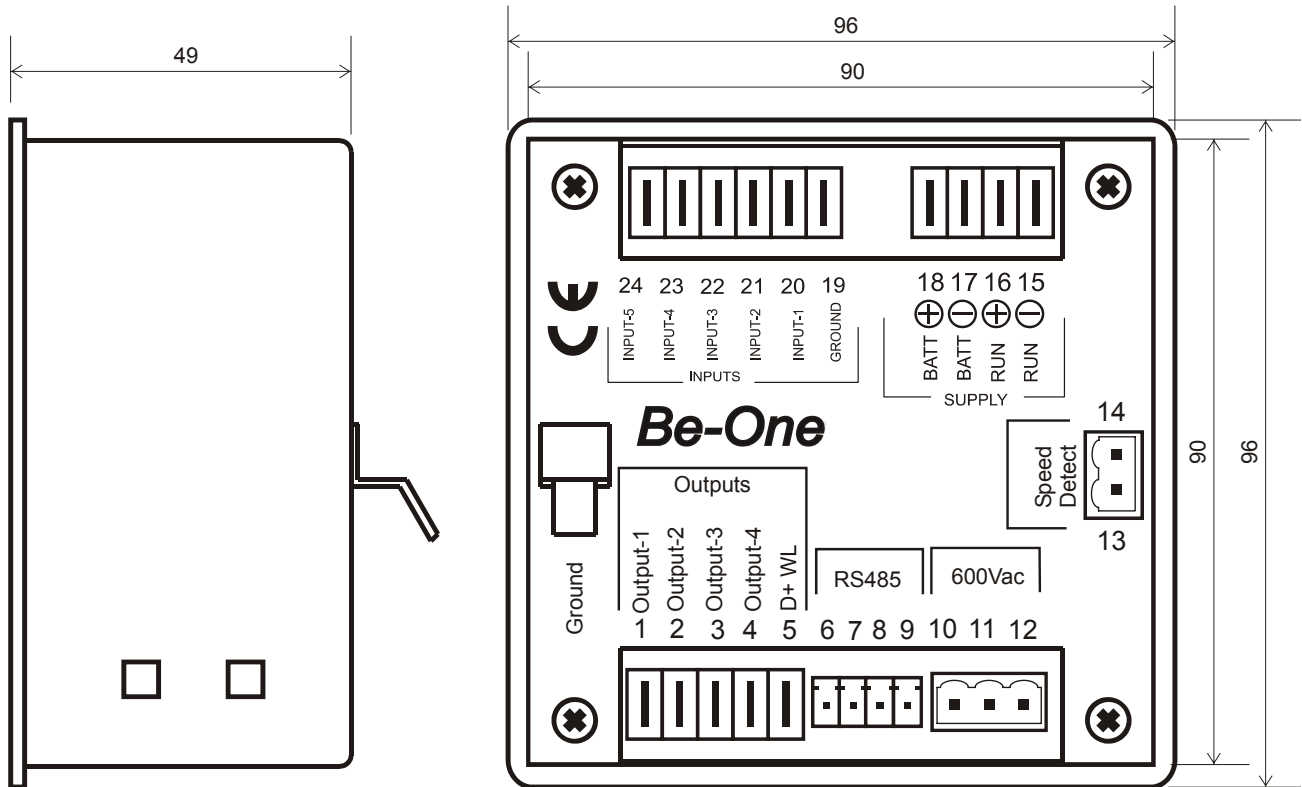

**Note: Drawing subject to change without notice**

**Section 19.0: Description of the connections**

Terminal	Description	Note	Section
1	Programmable output '1'	300mA Active 'Low'	7.08A-B
2	Programmable output '2'	300mA Active 'Low'	
3	Programmable output '3'	300mA Active 'Low'	
4	Programmable output '4'	300mA Active 'Low'	
5	Alternator Excitement output	Positive Output 3W	
6	RS485 Termination	See RS485 standard	See Be-one MODBUS user manual
7	RS485 Signal A	"	
8	RS485 Signal B	"	
9	RS485 Common Ground	"	
10	V Generator input Line or Neutral	Connect to the generator (max 600Vac)	7.01
11	Not connected		
12	V Generator input Line or Neutral		
13	Pick-up	Connect to pick-up, or the W terminal of the charger alternator	7.02
14	Pick-up		
15	Engine Running Minus detect	Connect to ground	10.0
16	Engine Running Plus detect	D+ or W.L. sensing	
17	Supply Battery minus connection	Internal 300mA fuse	13.0
18	Supply +12 or +24V Battery connection		
19	Common Sender ground sense	Ground connection	17.0
20	Programmable input '1'	Sensor or Switch	7.07A-B
21	Programmable input '2'		
22	Programmable input '3'		
23	Programmable input '4'		
24	Programmable input '5'		